



magazine

*Our outlook
for tomorrow
is our present*





page
02

News

page
06

Products

page
22

Our Company

page
32

Partnerships

page
36

Events

New Products Time-line 2022

2022

ICS Inductive
round sensors
JANUARY



SL series
E-STOP with protection
APRILE

FEBRUARY
HP series
Limit switches
with remote reset



News





Double pushbutton
restyling

JUNE

IQS Inductive
cubic sensor

JULY

MAY

New SB series
enclosures

JUNE

New triple
pushbutton



New General Catalog 2022

COMEPI's General Catalog 2022 has three sections dedicated to 3 NEW PRODUCT RANGES:

- Proximity sensors
- Lift devices
- Wireless Batteryless devices

This choice results from the need to simplify the consultation of our catalog by connecting some products to their specific design use. It also aims at enhancing the new product ranges that Comepi has inserted in their portfolio.

1. Safety devices

2. Limit switches



3. Proximity sensors

4. Lift devices

5. Control unit

6. Foot switches



7. Wireless Batteryless devices

News



Interruttori di finecorsa

Sensori di prossimità

Dispositivi per ascensori

Unità di comando Ø 22

Interruttori a pedale

Wireless

- **New product ranges**
- **New layout**
- **Product News**

5.Comepi

News

Proximity sensors

ICS series - Inductive round sensors

The gray section dedicated to proximity switches, and specifically to inductive round sensors, is one of the NEW PRODUCT RANGES in the COMEPI catalog.

COMEPI started 2022 with this important innovation, adding four series of devices with diverse dimensions and characteristics. This makes a total of 16 new products suitable for multiple applications

A new project to extend the company know-how and those solutions that we can offer to the market while maintaining the very high-quality standards that identify our products.

Products



ICS series - Inductive round sensors

Main features

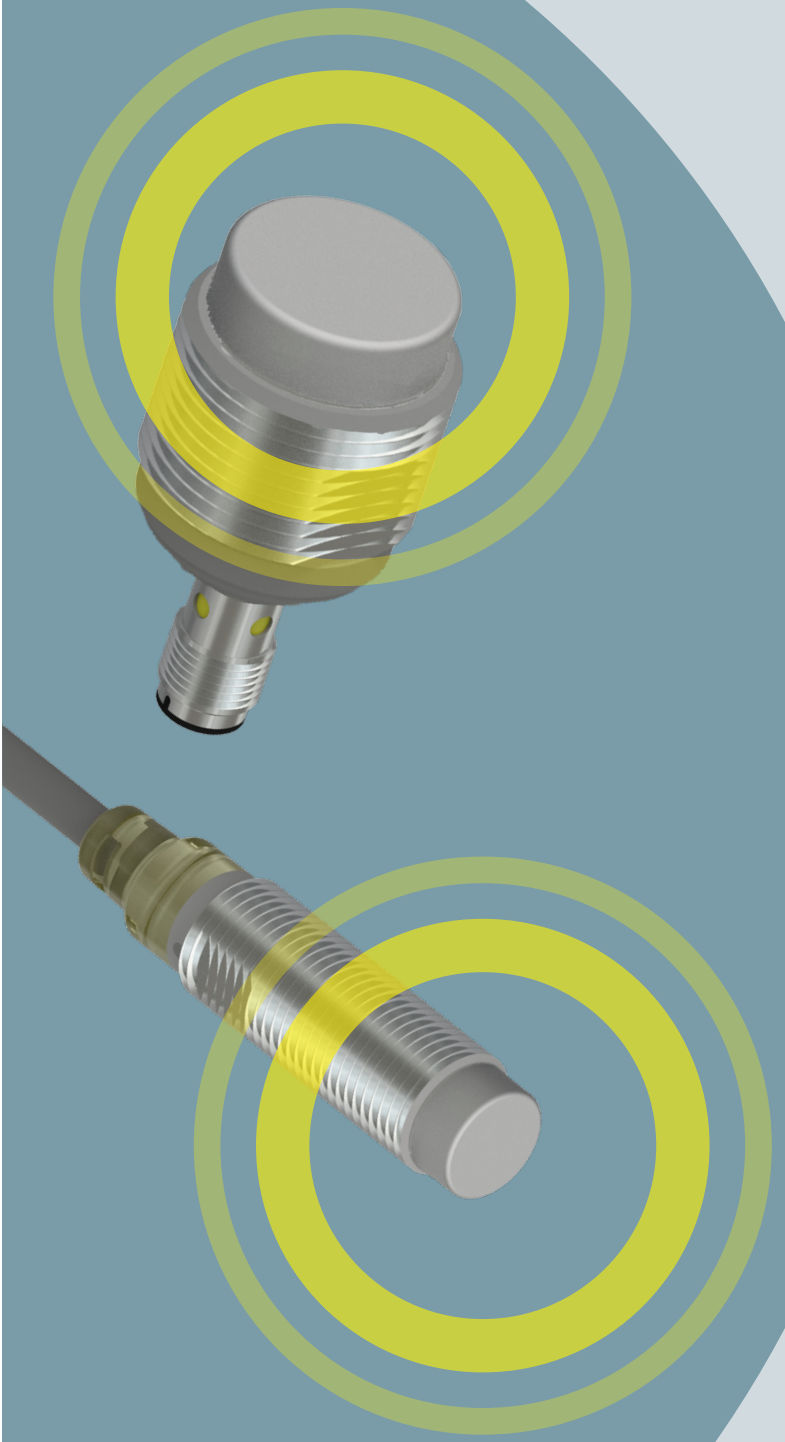

- They signal the presence of a metallic object up to 22 mm away
- Robust and reliable construction
- Available with diverse position distances
- M8, M12, M18, and M30 housings, in either stainless steel or nickel-plated brass
- Flush or NON Flush mounting
- Operation guaranteed in a temperature range from -25°C to +70°C
- IP67 Protection degree
- Compliant with International and European regulatory requirements

ICS series - Inductive sensors

Applications

The ICS-series is robust and highly reliable and can be used in a variety of fields such as:

Machine tools

- Numerical control machining centers
- Tools checks

Inductive sensors help verify either the position of a tool being replaced or the correct movement of a component to the correct position.

Agriculture and construction equipment

Thanks to its excellent quality and complete range of products, the ICS series is specially recommended for the agricultural and earth moving industries.

Material handling and production line systems

Automation and reliability of the goods flow must be ensured in these systems. Inductive sensors are essential to obtain higher productivity and quality from the process.



Products



ICS series - Inductive sensors

Applications

An example of application is provided by COMEPI where one of our new inductive sensors has been installed onto a piece of equipment used for testing the mechanical durability of our devices.

Sensor ICSMB30F04P1020 is the ideal solution for very dusty and dirty environments. It guarantees excellent reliability in applications requiring a higher number of operations.

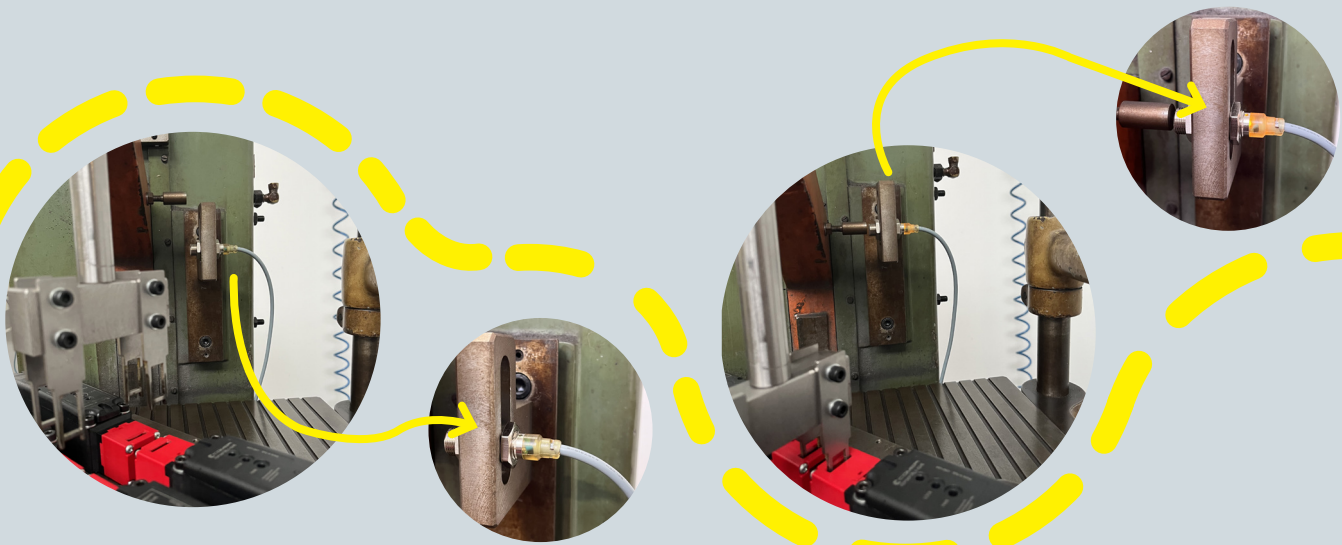

Comepi talks about

Dario, our Product Manager, notes:

“Rolling out a new product is always an important event for a company. However, in this case, I feel that this is a particularly special occasion.

We are not only launching a new range of devices on the market, but we are also opening up a brand-new section of our catalog.

For me, this means new ideas, projects, opportunities and, most importantly, new challenges that we are ready to take on.

Our inductive sensors embody all the above as well as our eagerness to learn and improve the skills of a company that does not ever want to stop moving forward”.



Inductive sensors

New IQS cubic sensor

Inductive proximity sensors sized 40mm x 40mm help detect metallic objects without contact or wear and are especially suitable for dirty and dusty environments.

These sensors generate an electromagnetic field that interacts with the detected object. They also have a long service life and are extremely robust. Their long-distance detection up to 40 mm makes them most highly suitable for use on conveyor belts. They provide stable detection in difficult environments thanks to their advanced integrated electronics that ensure optimum performance in high temperature variations.



Products



Inductive sensors

New IQS cubic sensor

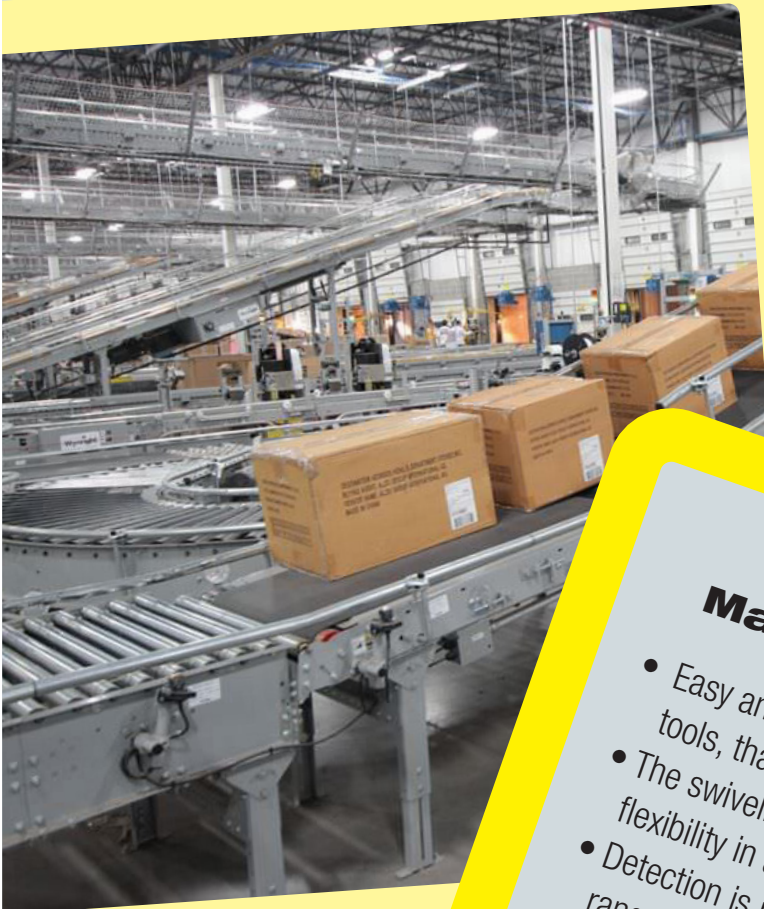

Applications :

- Logistical hubs
- Production lines
- Roller conveyors and handling systems
- Automated warehouses
- Escalators

Main features:

- Easy and fast assembling or replacement without using extra tools, thanks to the plug&play assembling system.
- The swiveling head in different positions allows for maximum flexibility in all applications.
- Detection is reliable and precise over the entire temperature range thanks to its advanced integrated electronics.
- Safer installation as a result of its long detection beams up to 40 mm.
- Switching is possible even in difficult environments with low and high temperatures (from -25°C to $+80^{\circ}\text{C}$).
- The sensor switching, and operational status is visible from any direction thanks to 4 angular LEDs.
- Diagnostic functions integrated with flashing LEDs in the event of either short circuits or overloads.

Lift devices

Overview

Products



SPEED LIMITER DEVICES



AP-DP series LIMIT SWITCHES



ROPE-OPERATED LIMIT SWITCHES



ACCESSORIES



DOOR CONTACTS



INDUCTIVE SENSORS



SL series E-STOP DEVICES



MODULE FOR CAR LEVELLING WITH THE FLOOR



LED LAMPS

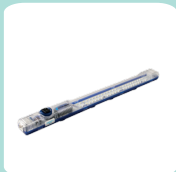

LIMIT SWITCHES WITH MANUAL RESET

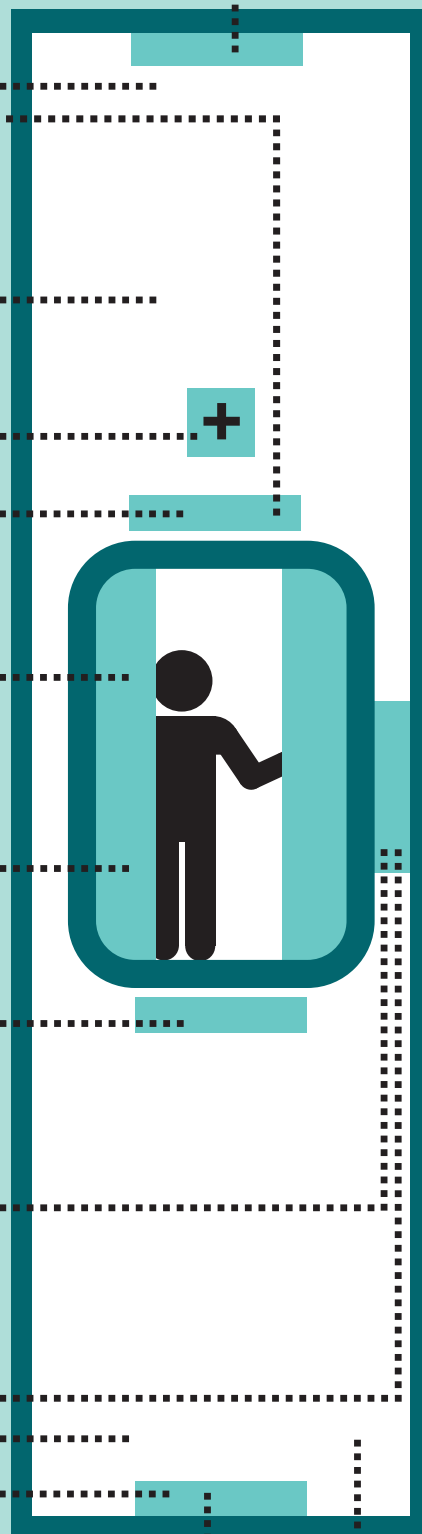

Lift devices Position

CAR ROOF
DEVICES



CAR UNDERSIDE
DEVICES



PIT DEVICES



LIFT WELL
DEVICES



DOOR
CONTACTS

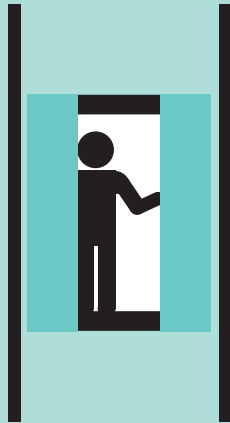

SPEED
LIMITERS



CONTROL
PANEL
COMPONENT



ACCESSORIES



Products



THE BEST PARTNER TO LIFT UP YOUR PROJECT

Limit switch with remote reset

New

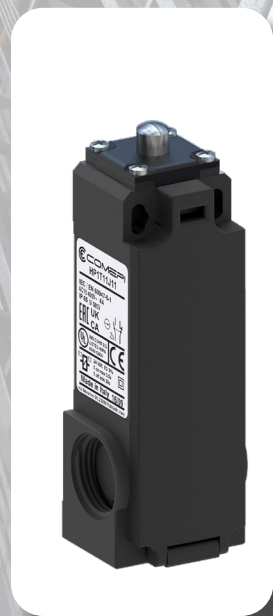

SPEED LIMITERS

These limit switches are made of fiberglass reinforced UL-V0 thermoplastic resins. They provide double insulation and IP65 protection degree. Being equipped with a solenoid-controlled remote reset system, they are ideal in a variety of applications where manual intervention is required to reset a circuit but manually resetting the device can be difficult. They comply with European Directives (Low Voltage, Lift Safety, and RoHS) as well as with European and International standards.

Main features:

- Electromechanical limit switch with remote reset
- Solenoid-controlled reset (supply voltage of 24Vdc or 230Vac)
- Diverse heads available, including the manual reset version
- Normally closed contacts with positive opening
- Versions equipped with 1NO+1NC or 2NC available
- Very high degree of protection against water and dust (IP65-IP67)
- Very long service life (50.000 operations) and certified reliability

SL series E-STOP

New



CAR ROOF
DEVICES



CAR UNDERSIDE
DEVICES



PIT DEVICES

The new series of SL enclosures was specifically designed for applications in lifts. It now comes with a new emergency stop device with integrated protection. This device is equipped with our mushroom-like pushbutton type ECX 4580 (with rotary release) certified for emergency stop according to IEC 60947- 5-5 and EN ISO 13850 standards.

Our E-STOP SL-series device can also be supplied with various contact configurations to give our customers a ready-to-use solution for any application. The integrated protection also allows for foot-controlled activation and protecting the pushbutton from damage caused by it being trampled upon.



Main features :

- Cover with integrated protection
- Foot-controlled activation
- IP65 degree protection
- Compliant with EN 60947-5-5 European standards
- Supplied with emergency pushbutton ECX 4580
- Possible fixing with screws or magnets

New plastic pushbutton enclosure **SB series**

During the last SPS Parma trade show, we rolled out our new SB series pushbutton enclosures that aroused great interest in the visitors.

The SB113 single position enclosure is only the preview of a growing series that will be characterized by a brand-new design and interesting functions.

A series of thermoplastic enclosures aiming at being ranked top of the range for both performance and operation.



TOP

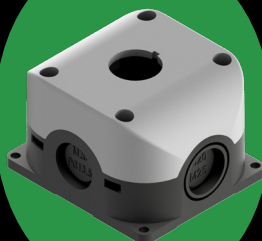

Products



New plastic pushbutton enclosures

SB series

MAIN FEATURES:

- Stainless steel fixing screws
- Compatible with pushbuttons of 22mm in diameter
- In fiberglass reinforced polycarbonate
- Robust construction for applications in difficult environments. Designed to achieve IP69K protection according EN 60529
- Equipped with small bolts for a safe and comfortable closure of the cover
- Gasket on deposit for best sealing performances
- Hook-in contacts with fixing to the enclosure bottom
- 6 knockout holes in different dimensions
- UL-approved self-extinguishing materials
- Double option of fixing, without opening the enclosures
- Possible magnetic fixing with magnets

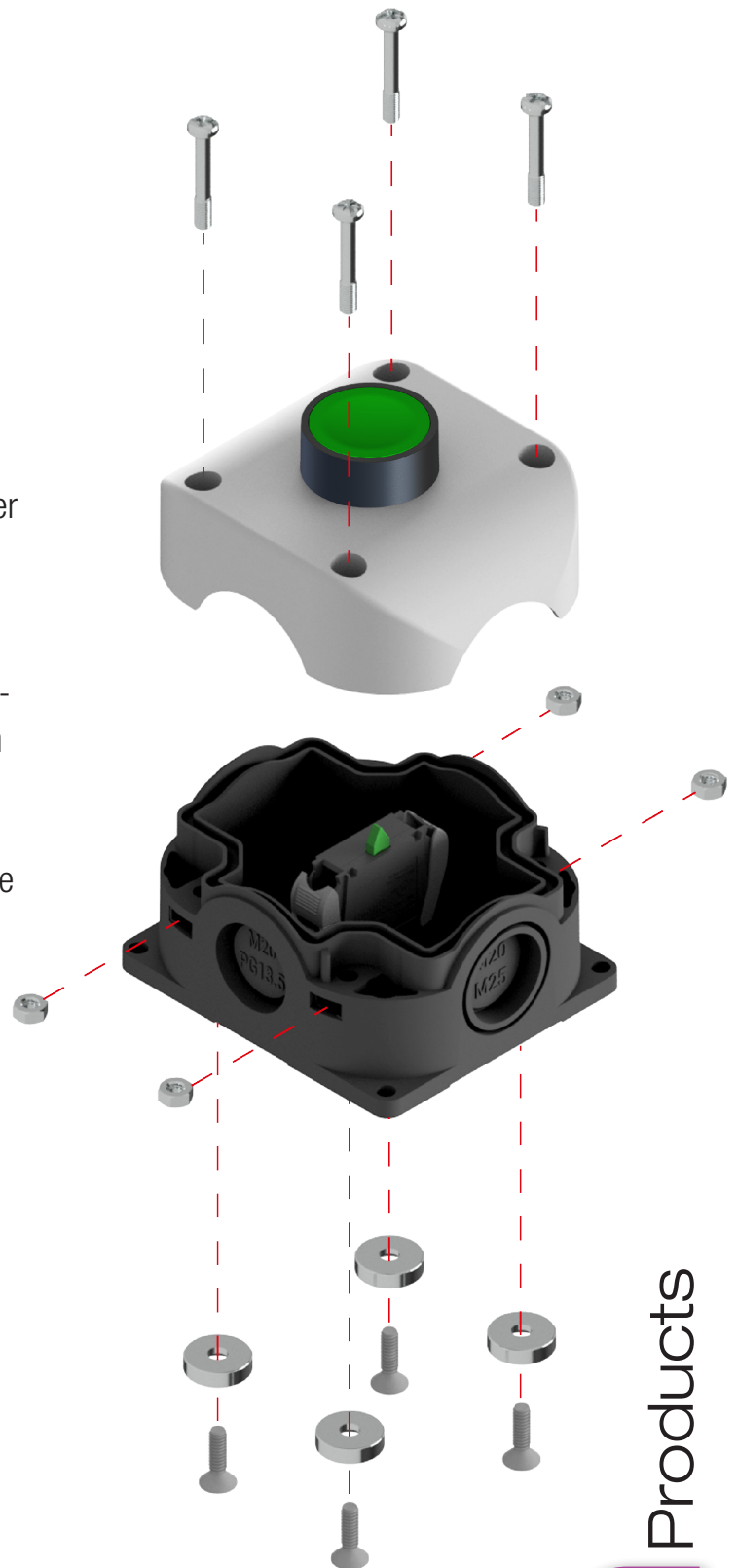

Products

New plastic pushbutton enclosures

SB series

The construction characteristics of the SB enclosure ensure excellent performance, high functionality and multiple applications.



1

Use in harsh environments and extreme climate conditions

2

Cable and maintenance simplicity



Products



New plastic pushbutton enclosures

SB series

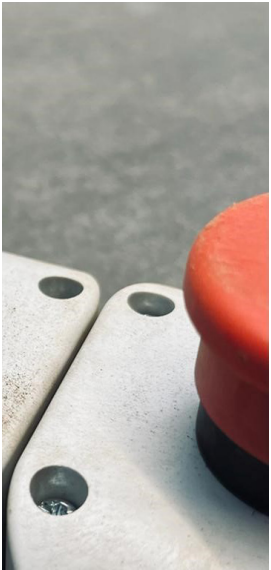

3

Diverse installation options according to one's needs



IP69K protection for high-pressure washing and high temperatures

4

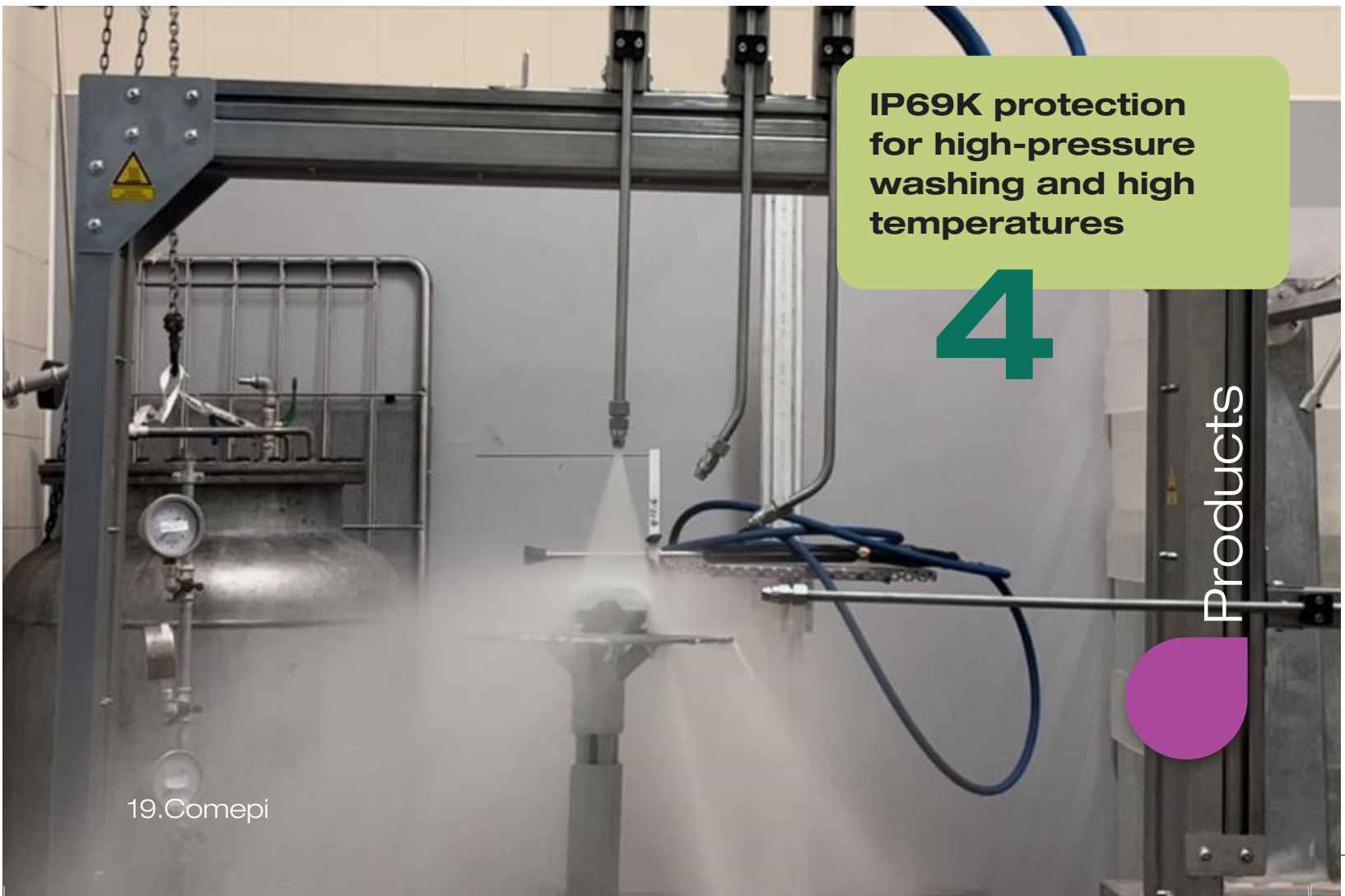

Products

Duouble pushbuttons

Restyling

- **New ergonomic design**
- **Includible indicator light**
- **Flush or extended**
- **Various configurations and symbols**
- **IP65 Degree protection**

- ● Flush ferrule
- ● Flush ferrule
- ● Flush ferrule
- ● Flush ferrule with I-O symbols
- ● Flush ferrule with I-O symbols
- ● Flush ferrule with I-O symbols
- ● Flush ferrule with START – STOP indica-
- ● Flush Ferrule with arrows ↓ ↑
- ● Protruding
- ● Protruding
- ● Protruding
- ● Protruding with I-O symbols
- ● Protruding with I-O symbols
- ● Protruding with I-O symbols
- ● Protruding with START - STOP indications

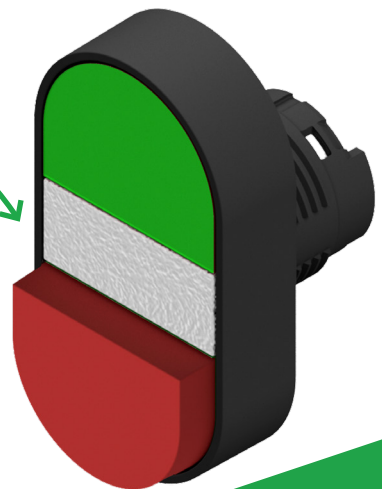

Products



Triple pushbuttons

New



- **New version with three operators**
- **A whole array of configurations and symbols**
- **Extended STOP pushbutton**
- **IP65 degree of protection**



Products

Comepi Team Logistics Warehouse Department



TIDINESS

ORGANIZATION



trackability



**“One’s destination is never a place,
but a new way of seeing things”**

Henry Miller

Our company

Michele, has been working at COMEPI for 15 years. Currently, he is the Warehouse Manager in charge of its maximum efficiency with multiple activities of loading, unloading, goods handling, packing, and shipment.

A travel lover, he was a tour guiding for tourists in amazing adventures in the desert and in the most spectacular places of our planet.



Wireless Batteryless Warehouse logistics applications

Last February, our Swedish distributor OEM AUTOMATIC AB released a commercial showing the various application of Comepi's Wireless Batteryless products very clearly.

**“No more wiring or batteries!
Put your switches wherever you want and
select the function they should provide.
Exactly like Nils shows in the video.”**



Our company





Team Comepi Push-button Department



efficiency



ORGANIZATION



SINCE
1980



“People are a company’s
real value.””

This quote introduces **Orietta**, one of our most valued supervisors. In her 29 years in COMEPI, she has witnessed the growth of the company whilst she has grown with it. Calm and resolute, she faces with and manages at best even the most intense workloads in addition to coordinating all of the department activity. A lover of animals and nature, her family includes 2 dogs, 2 cats and 2 couples of inseparable small parrots.

Our company



Team Comepi Customer Service

Customer Service is one of COMEPI's strong points that has always paid the utmost attention to the customer and provides high-level support rapidly. Our Customer Service team is made up of several individuals who, thanks to their specific skills, can meet all of the requests for technical, commercial, and logistics assistance.

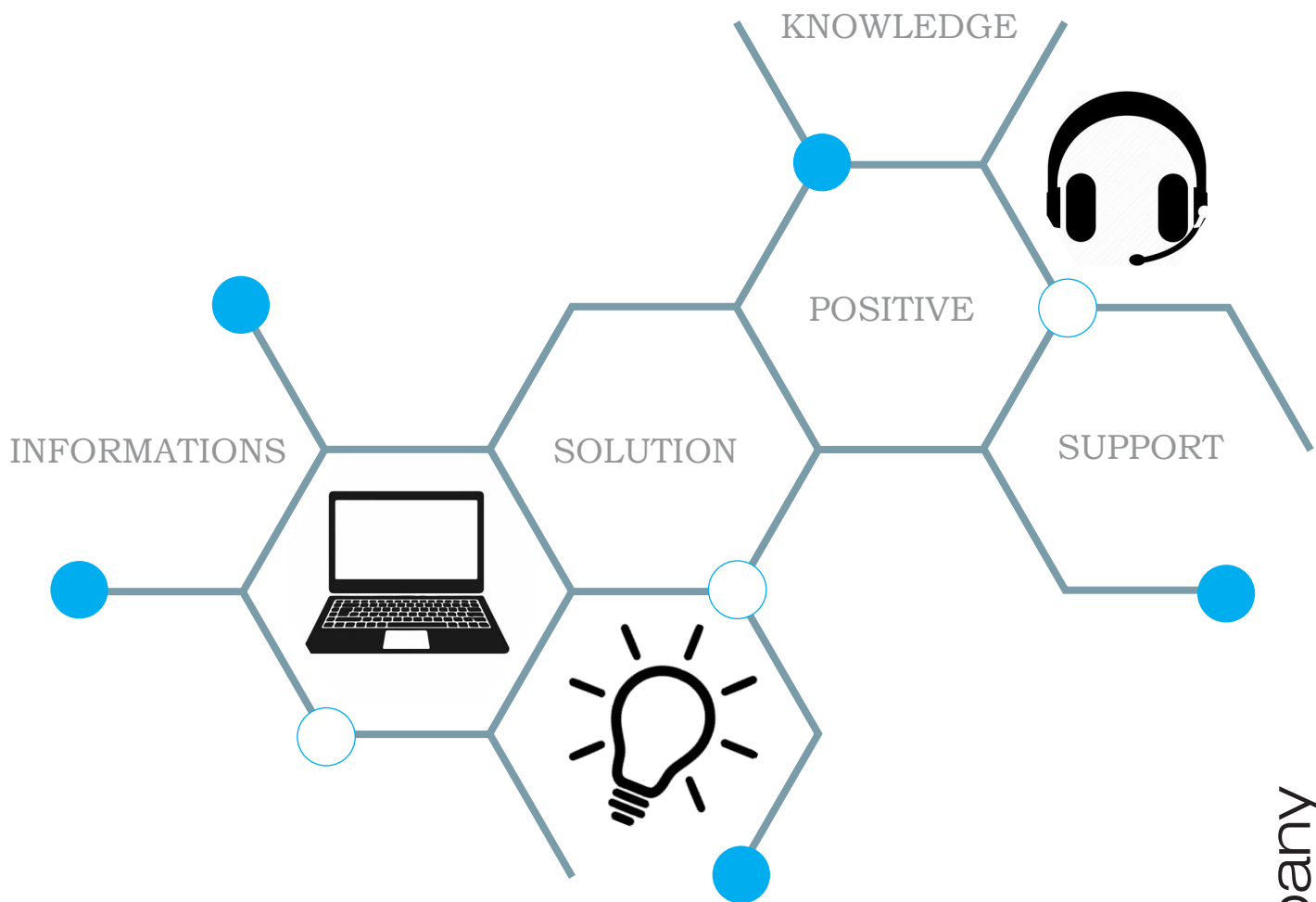

A TEAM always available for our customers!

Our company

Team Comepi IP67 Pre-wired switches department

ACCURACY

Teamwork

PACE

Good morning, ladies!!

This is how **Sandra** has started her working day at Comepi for the last 16 years now.

The supervisor of the pre-wired devices production lines, she coordinates the work of her 6 member team with great energy. A joyful and lively person, she loves interacting with people, travelling and discovering different places and realities.

Our company



IP67 Pre-wired switches

Applications

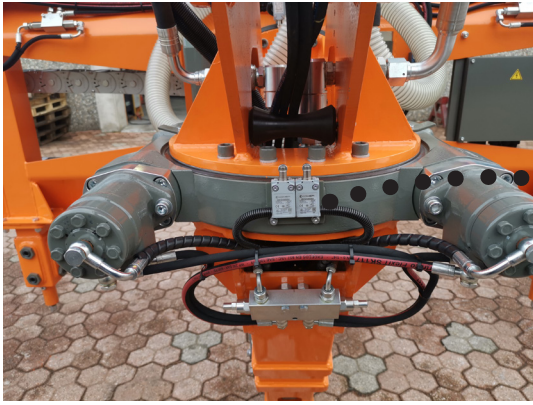

COMEPI pre-wired switches are ideal for a variety of applications thanks to their robustness, reliability and possible customization.

Marini Quarries Group, a worldwide leading manufacturer of machinery and equipment for drilling and diamond wire cutting in marble and granite quarries, provides a remarkably interesting application example.

Our EM1G14X020UP limit switch that has been installed there has, in this case, been equipped with a cut resistant PUR that is particularly flexible.

This product ensures an extremely high IP protection degree, robustness and efficiency even in very harsh work environments.

- Robust metallic casing
- IP67 Protection Degree
- Very high metallic service life
- PUR cut-resistant cable for mobile flexible installations

Our company

MARINI
QUARRIES GROUP



Team Comepi 40mm Limit switches department

STRENGTH

History & Tradition

Great
dexterity

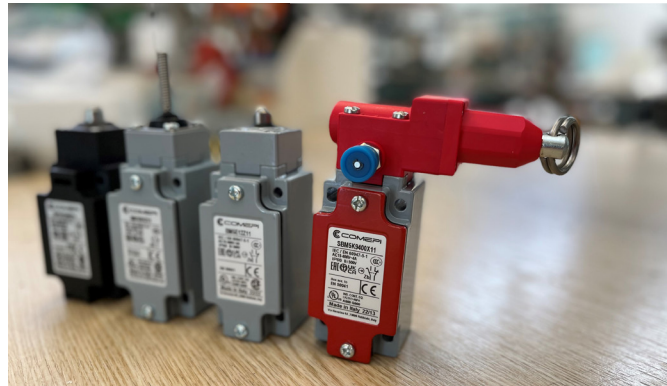

Antonella, the manager of our 40 mm limit switch department, is one of the key players of our production.

She joined Comepi 27 years ago and supervises our limit switch production for heavy applications of which she knows each and every detail and specification.

A cheerful and plainspoken lady, she always has a smile for everyone.

Family is her priority, and she is a cooking enthusiast.



Our company



Certifications

ISO 9001:2015 Renewal

COMEPI first obtained the ISO 9001 Certification for the quality management system back in 1988, which guarantees our reliability to our customers. Recently we updated our Compliance Certificate to ISO 9001:2015 that is now available for reference on our website.

A solid company with a great legacy of quality.

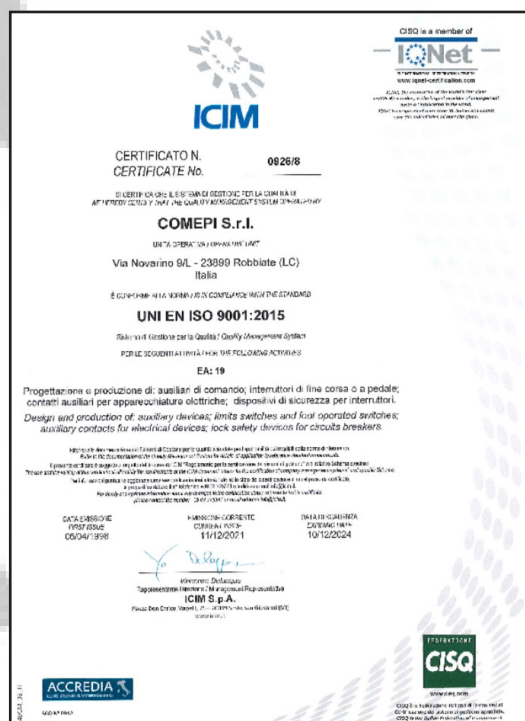

SINCE
1998

29.Comepi

Our company



Industry 4.0 Plan

New laser machine

Less waste and better results?

That is possible based on our improved production lines!

At our factory in Robbiate, we have recently installed an automatic laser marking station for microswitches using our limit switches, foot switches and safety devices.

The new laser machine means important improvements:

- More accurate, unerasable component markings.
- Improvement of the design process with the new marking loaded onto the machinery directly from remote by our designers.
- The production flow has been optimized. Now, orders are directly output from our management software while the production status is being monitored in real time, as it applies to the available stock for example.
- Sustainability of our products has increased having removed the use of paper tags.

A great result,
the starting point for
new improvements and projects!

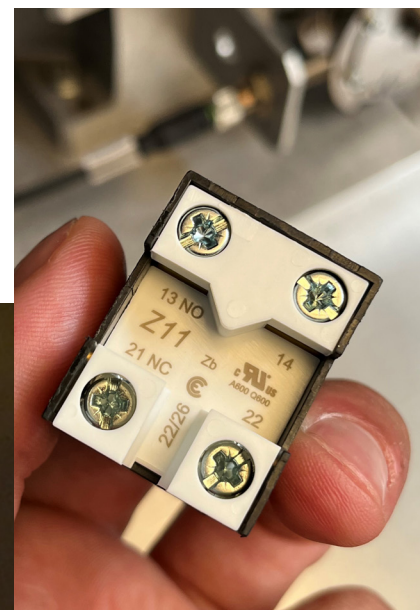
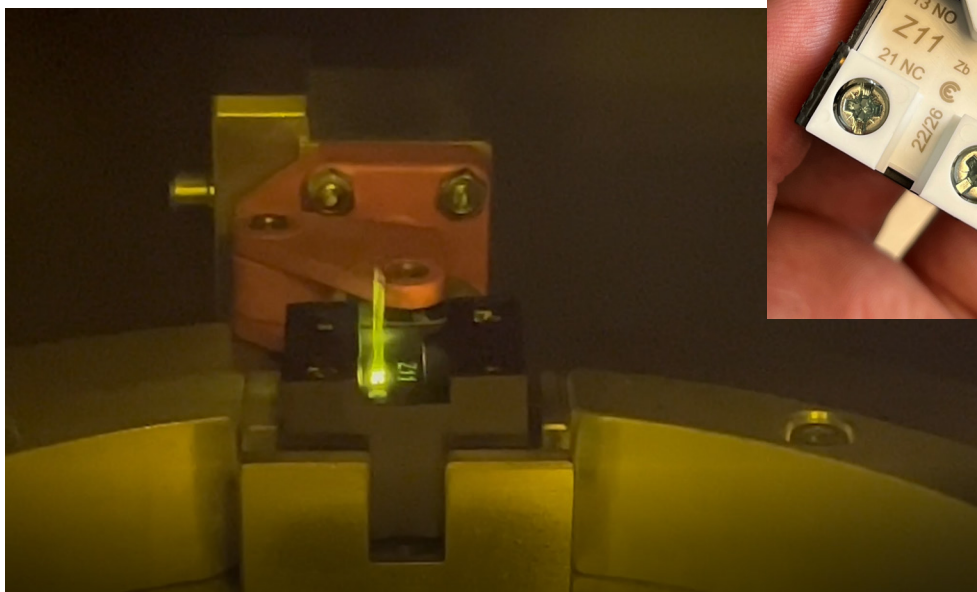





Industry 4.0 plan

Industry 4.0 Plan is an important step in the digital transformation also for SMEs like ours.

We are currently implementing some technological solutions in our business context in order to both optimize and automatize our production processes and create a real time connection between products, machinery, equipment and staff to obtain an interconnected management

From the Industry 4.0 Plan implementation, Comepi expects the following results:

-  **productivity increase**
-  **enhanced production flexibility**
-  **higher quality levels**
-  **real time monitoring**
-  **new business opportunities**

With this in mind, we are entering the “**fourth industrial revolution**” as many describe it.

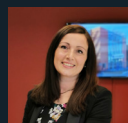

Greta Manzoni
Operations Director



Safety modules

An example of application

Our safety modules series MS1 comes in five variants and permits our customers to use a product that is perfectly suitable for their application. Global Concept s.r.l. exemplifies the foregoing. For more than twenty years this Tuscan company has described itself as a reliable partner specialized in the control and management of industrial systems, telecommunications and automatic machineries.

In this interesting application, our MS1A20-024 safety modules have been installed inside the electrical command and control panel of a railway maintenance platform made up of lifting columns and trolleys for disassembling the wheels and the components under the trains.

Version MS1A20-024, equipped with 2 NO safety outputs, gives our customer an advantage in terms of costs with respect to the MS1A31-024 one though ensuring the same functional and safety performance of the standard version.



Partnerships



Safety modules

An example of application



Reliability and user-friendliness are some other appealing features of our MS1. Such qualities are ensuring that this product is rapidly gaining market share.



Gioppe S.r.l. is another company using our devices. This company in the northern Milan area delivers advanced solutions for handling and packaging in the textile industry across the world

The installed MS1A31-024 safety module allows them to safely control the machinery emergency stop thanks to a two-channel configuration ensuring highly efficient safety performance.

Really an excellent result!



MS1A31-024 Safety module

- Ideal to control emergency stops
- Quick and intuitive connection
- Limited volume within the electrical panel
- PL Performance Level and certificate under EN ISO 13849-1



Partnerships

Comepi & Henkel Partnership



In COMEPI, the success of a project also relies on our suppliers and their ability to lead us to the achievement of our preset goals with their specific skills. Our long-standing collaboration with Henkel Italia has always fallen within this frame. Their experience was also crucial in the incredible success of the project for the new SB pushbutton panels.

Some quotes from Henkel on this success:

“When Mauro Balbiani, Henkel Italia Sales Area Manager, receives a phone call from COMEPI he is always happy. He knows that the R&D department always has new and interesting products to submit for evaluation, making him an integral part of the project team as an outsourced supplier.

One of the requirements of the new SB pushbutton panels developed by COMEPI was reaching the IP69K level so as to guarantee the seal against humidity and dust, even under high-pressure and temperature, hence protecting the electronics inside the product.

The challenge for HENKEL was to find suitable sealing foam as the regular low viscosity PU 2K could not be used due to the gradients along the housing groove profile.

Henkel searched for chemically efficient solutions to meet this specific design requirement. At the Oggiono (Lecco) factory a whole series of tests were made on 3D print prototypes that resulted in the development of a new medium-thixotropic polyurethane material.

Partnerships



Comepi & Henkel Partnership

At the same time, COMEPI began evaluating the necessary modification to the mechanical part in order to deploy the FIPFG (Formed-In-Place-Foam-Gasket) technology for the material automatic deposit. FIPFG technology is applied even when there are small casing and narrow grooves, where dosing quantity is very much reduced, and the application must be accurate.

The mixing head mounted on a specific CNC working table delivers sealing PU 2K foam in the groove with high dosing precision hence making production repeatable also on very high numbers of lots. The result of such work is so precise to the extent that it is practically impossible to detect the cycle closing point with the naked eye. The result is a seamless gasket without any deformities that could compromise its sealing.

Henkel's foam also possesses the excellent ability to reset the original shape, even after years of application. Hence, the user can open and close the enclosures for installation and maintenance purposes with no changes to the original IP protection degree.

After a few months of work, thanks to the modified geometry by COMEPI and the development of the new medium-thixotropic material by HENKEL, we jointly succeeded in developing the SONDERHOFF FERMAPOR K31 two-component polyurethane foam gasket to meet the strict design requirements!"



SPS Parma 2022



**Ideas, technologies
and teamwork!
Our return to the SPS
Italia trade show
was an
enormous success!!**

sps
ITALIA
smart production solutions



Events



SPS Parma 2022

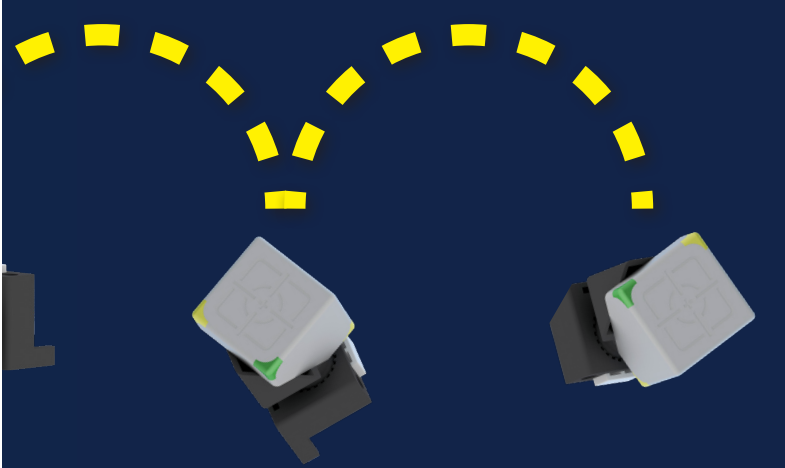
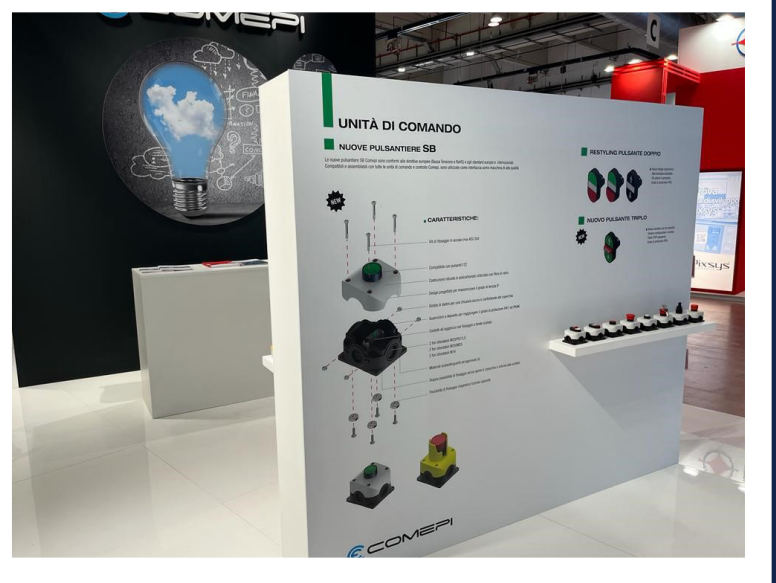

**Thanks to all
our visitors!**

Events



Interlift 2022

From 26th to 29th April 2022, COMEPI debuted in the INTERLIFT trade show in Augsburg, Germany, presenting their new range of products dedicated to the lift industry.

Registration for the show's next edition to be held in October 2023 has already been confirmed.

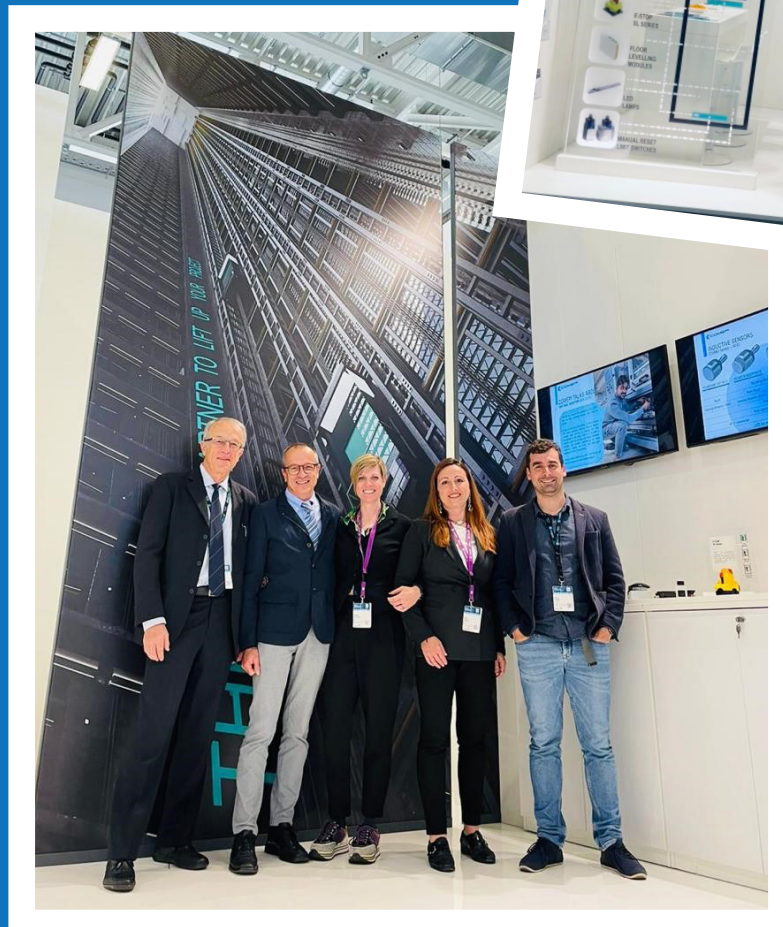
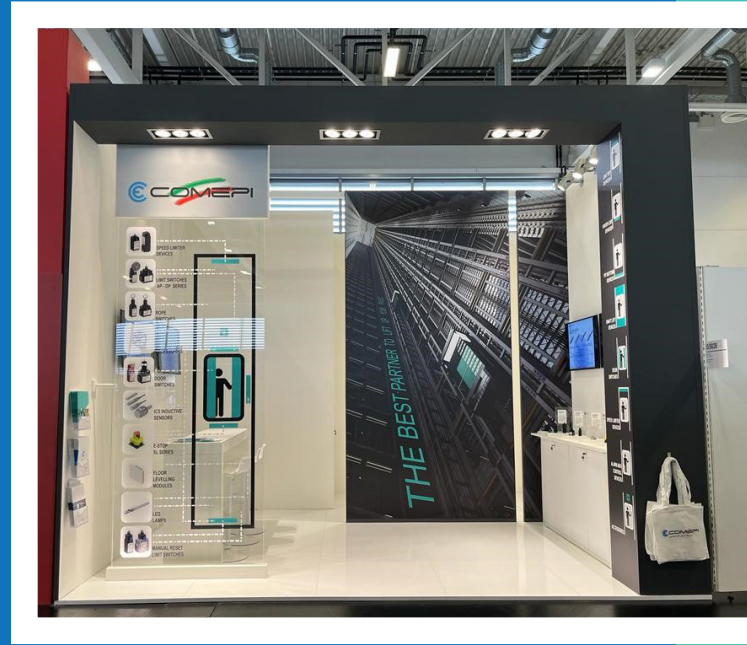

Events



38.Comepi

LogiMAT 2022

LogiMAT is the biggest and most important trade show for Intralogistics Solutions in Europe. COMEPI's participation in this exhibition was an important opportunity to know new intralogistics and process management solutions as well as to get new application ideas and contacts for promoting our new wireless batteryless products.

Also in this case, COMEPI has already confirmed its presence at the next edition scheduled in April 2023.



think
outside
the BOX

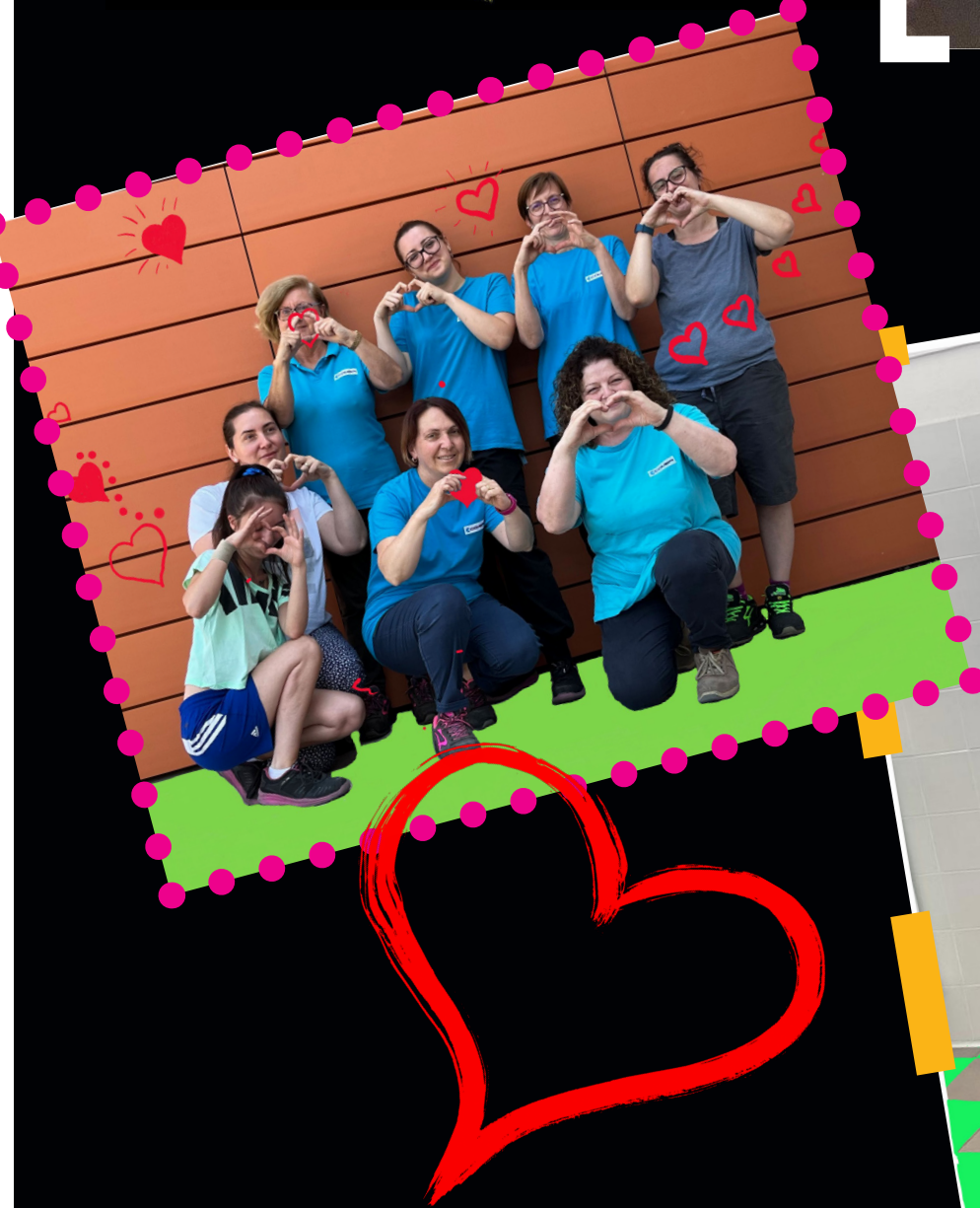



23899 Robbiate (Lecco)
Via Novarino 9/L
tel. +039 9903468
+039 9906408
comepi@comepi.it
comepi.eu



LUG2022-03E