

02 January
2022

magazine

Change

PEOPLE

INNOVATION

Results





page
02

News

page
06

Products

page
18

Our Company

page
32

Partnerships

page
34

Events

New products timeline 2021

2021

Limit switch with
M12 Connector

FEBRUARY



MARCH
Revamping of SMP2
magnetic sensors

SA E-STOP with
knockout holes

APRIL

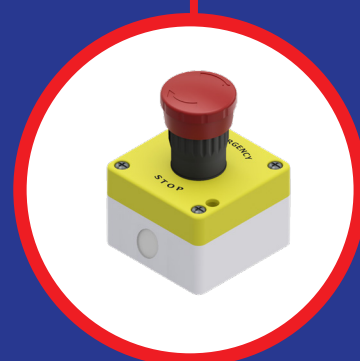

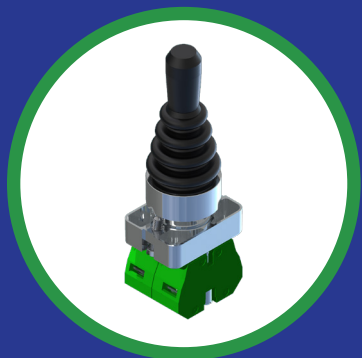

T80 Lift
door contact

JULY



22mm Pushbutton
DIN bar adapter

DECEMBER

JUNE

Improvement of
maintained
joystick switch

OCTOBER

New safety microswitches
for the FEP series

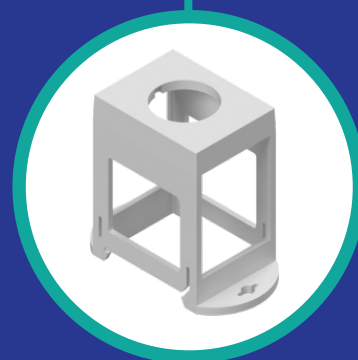



comepi.eu A New Home Page

Our www.comepi.eu website has been updated with **a new homepage!** We have revamped its design with a **more modern and functional** look, starting from the adding of a top menu that makes browsing so much easier.

A new scrolling banner shows the **main concepts of the company's mission**: the enhancement of Made in Italy products, the attention to innovation, and a look towards the future.

Three additional new navigation links (news, literature and magazines) make accessing the main contents **more immediate and usable**, as is the case for instance for this magazine that you can read and browse through directly online.

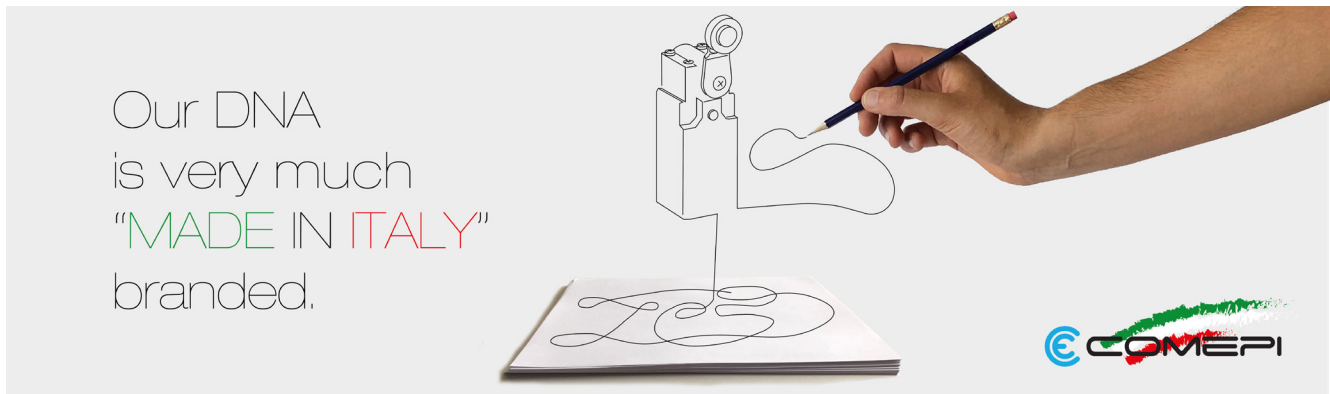

Our DNA
is very much
"MADE IN ITALY"
branded.



Innovating being
able to both take risks and
accepting the challenge
to change.

News

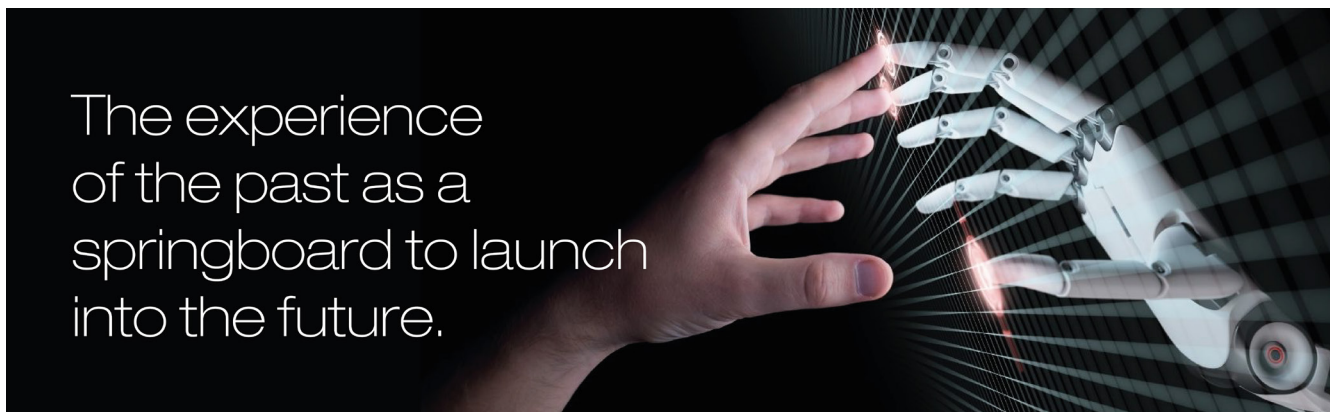

The experience
of the past as a
springboard to launch
into the future.

comepi.eu
Our new colors



**PUSHBUTTONS AND
PUSHBUTTON PANELS**



LIMIT SWITCHES



SAFETY



FOOT SWITCHES

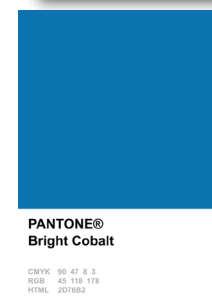

WIRELESS SYSTEMS

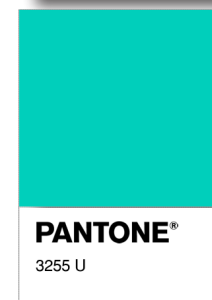

DEVICES FOR LIFTS



News



T80 Lift door color

NEW

A new type of limit switches has been added to our catalog with a **new solution** for specific applications.

Our **T80 device is a switch for sliding doors** designed for applications on **passenger and goods lifts**, with IP67 protection degree and the positive opening of the 1NC contact.

It comes in the AP version (Thermoplastic 30mm) and DP (Thermoplastic 50mm with two cable inlets). It ensures **maximum reliability and flexibility in its use** even in particularly demanding applications like the electrical system performance, such as emergency or external lifts.



Main features:

- IP67
- Positive opening
- Compliant with EN 81-20 and EN 81-50
- Swiveling head
- Adjustable actuator included



AP_80

30 mm
1 cable inlet



DP_80

50 mm
2 cable inlets

T80 Lift door contact

Applications



The ideal solution for:

- Humid environments
- External lifts
- Emergency lifts
- Firefighting lifts



Devices for lifts

Limit switches for speed limiters



In the new product category focused on applications on passenger and goods lifts, Comepi proposes its **R002 Limit Switch**, a product specifically designed for applications on **speed limiters**.

This device comes with a 30mm plastic casing and **positive opening NC contacts** that are available in two different configurations. The product is also highly sensitive with the possibility to manually reset the actuator after operation.

MAIN FEATURES:

- Manual reset
- 1NO+1NC or 2NC configuration
- Compliant with market size standards
- Specifically designed for application in lift speed limiters



Devices for lifts

Limit switches with manual reset

Our limit switches with manual reset guarantee the interruption of the electrical circuit until the **actuator has been manually reset** by pulling the blue knob.

The range of these products includes a wide variety of heads and casings that are largely used in applications on **lifts and escalators** in compliance with standards and regulations in force.



**DP_R
Series**



**AM_R
Series**



**DM_R
Series**



**AP_R
Series**

APPLICATIONS:

- electrical lifts
- goods lifts
- escalators
- conveyor belts
- hoisting equipment



DIN ECX 2572 Bar adapter

For pushbuttons of 22 mm in diameter

Comepi's catalog is continually evolving also thanks to the new **ECX 2572** adapter. It makes it possible to install pushbuttons of 22 mm in diameter directly onto the DIN bar that is a useful accessory for multiple applications.

This product is made from a sturdy **fiberglass reinforced thermoplastic material**. It provides good connection and easy mounting despite its compact size.

The ECX 2572 adapter is compatible with **COMEPI buttons** series 4000 and 1000 hence allowing for the installation of 22 mm control units inside the electrical cabinet.

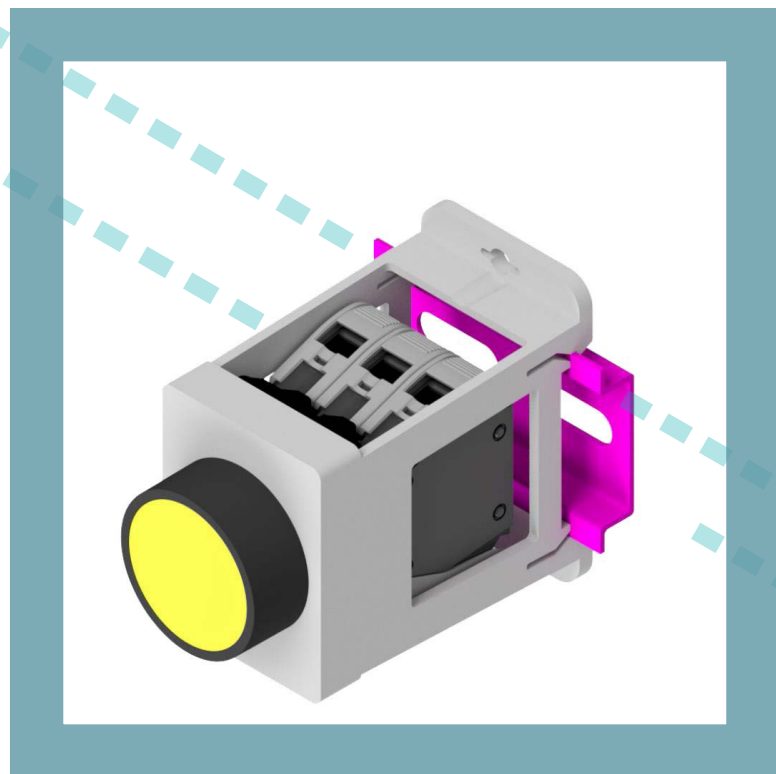

Products



- It permits the installation of pushbuttons directly inside the electrical cabinet.
- Hook fastening and compact dimensions
- Compatible with pushbuttons series ECX 4000 and ECX 1000

DIN ECX 2572 Bar adapter

Applications

Our adapter for DIN guides is easily installed and uninstalled hence ensuring **simple application** and flexible use.

Thanks to the quick hooking, 22 mm control units can be installed directly inside the electrical cabinet both quickly and safely.

This useful accessory is widely used in **electrical cabinets of passenger and goods lifts.**

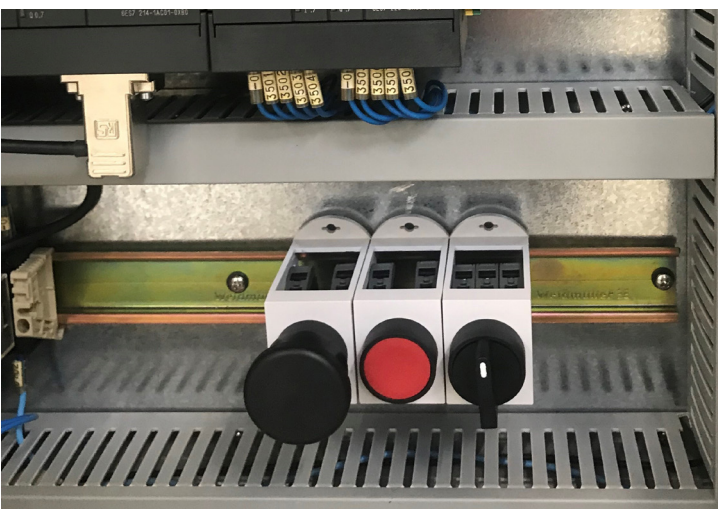

Hooking

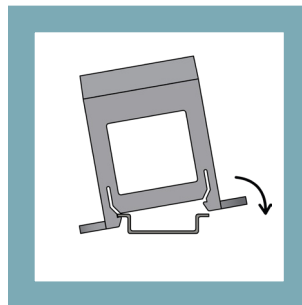

Releasing

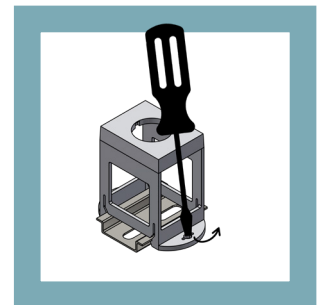

Comepi talks about

Simone, the designing engineer of this new product, tells us that:

“The DIN bar adapter for ECX 2572 was **my very first project from the very beginning to the end!**”

Following the whole process has been both exciting and stimulating. I began from the request for a product and ended up with the final components in my hands **with a lot of work** in the meantime like carrying out market surveys, creating 3D models, realizing laser sintered prototypes, designing the mold and anxiously waiting for the first samples. Appetite comes with eating, and I can't wait **to take on another challenge** for a new Comepi project!”



Safety interlock devices

New microswitches

COMEPI's offer of safety interlock electromechanical devices series FEP and FEP-LOCK becomes even more complete with **9 additional new types of microswitches**.

The new versions have been added to the three existing ones to ensure greater application possibilities and better integration of the device inside the **safety circuits** in a variety of machines and production lines.



9 new microswitches

with different contact types have been added to the existing ones

Products



	ACTUATOR	COIL
FA1	1NC	2NC+1NO
FA2	1NO	2NO+1NO
FA3	1NO+1NC	2NC
FA4	1NO+1NC	1NO+1NC
FA5	1NC	3NC
FA6	1NO	3NC
FA7	2NC	1NO+1NC
FA8	2NC	2NC
FA9	2NO	2NC
FB1	-	4NC
FB2	4NC	-
FB3	3NC	1NC

Safety interlock devices

FEP series: contact block function

Interlock devices geared **to block movable guards** have been designed in conformity with EN ISO 14119 standards. They perform two separate tasks, controlling the guard closing and blocking said guard.

These devices have an inside **electromechanical microswitch** that provides four output contacts for the user.

The microswitch interfaces with the outside and outputs electrical signals that univocally represent **the condition of the guard** onto which the interlock device is being applied.

A **safe and reliable** component that is also suitable for multiple safety logics based on the different NO and NC contact combinations.

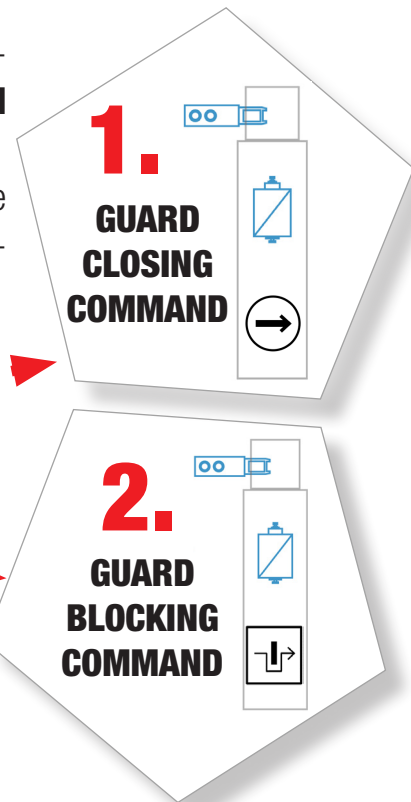
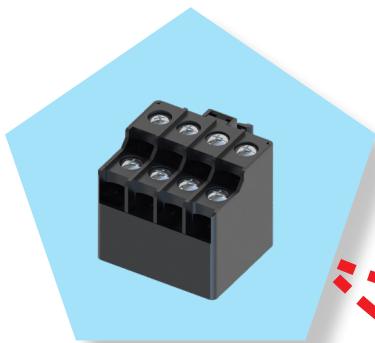

Comepi talks about

Egidio, our mechanical designer unveils this new project to us:

“Our response to the requests from the market for a wider range involved **a considerable amount of studying**. This helped us create these new types of microswitches while integrating a few simple details to what already existed. **Our 3D printer** was crucial in quickly realizing prototypes that permitted physically evaluating what we designed in short time.

In Comepi, we strongly believe in new technology as a way for developing products.

The successful finalization of this project is a further indication that we should **continue to proceed down the path of innovation.**”



Joysticks Overview and news

Joysticks
Metallic series

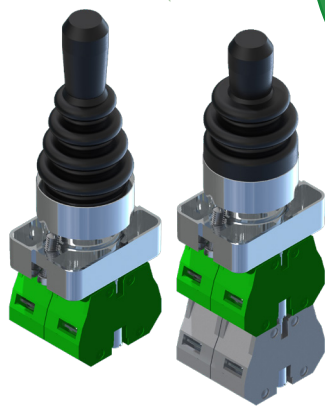

Joysticks
Thermoplastic series



Comepi joysticks have always been appreciated on the market for their **sound and solid construction**. This quality has made them best-sellers over the years.

A new **version with a flexible shaft** adds to the existing line of products. This variant proves to be especially suitable for precise, heavy-use applications for the device.

The revamping of models with **maintained position** was another innovation for 2021. Their resistance was improved to permit their use in applications subject to **severe shocks and vibrations**.

Products

Our range :

- With retraction
- Maintained position
- Multiple position
- Standard version h. 74 mm
- Compact version h. 55 mm



What's new?

- New joystick with flexible shaft
- Strengthening of the maintained position

Maintained joystick positions

Revamped range

In order to meet with the requests from the most demanding markets, Comepi has enhanced their **joystick with maintained positions** while strengthening their holding capabilities. Such an improvement has not impacted either on the product aesthetics or the user's feeling during use. On the contrary, **it increases the application possibilities** in the automotive industry or in the case of strong vibrations.

In fact, these new versions underwent **vibration tests** as required by the automotive industry standard ISO 16750-3.

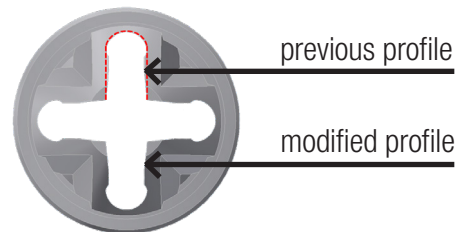
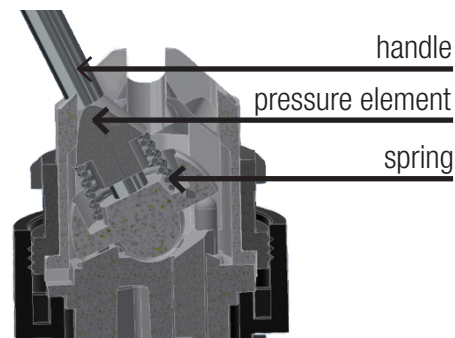

Comepi talks about

Davide, one of our engineers and mechanical designers, talks about this product revamping: “Thanks to a **half-century long experience** in the HMI market and the close collaboration with their customers, Comepi decided to widen the range of an historical product like the joystick.

The **unceasing research for customized and breakthrough solutions** is the key in the company mission to fulfill the most diverse application needs the market demands.

With this product updating, today our joystick can also meet the demand from particularly demanding sectors where **high sturdiness and resistance to vibrations is required**”.

Flexible shaft joystick

NEW

In 2021, Comepi widened their range of 22 mm handles with a very special item, the **joystick with a flexible shaft**.

Compared to its basic model, this device comes with a spring that provides **extreme flexibility of the lever** hence making commands sharper and with improved resistance to even the most extreme stress.

Its sturdiness makes this product the ideal solution in case of **harsh work conditions** and applications requiring foot control of the joystick.

As is their custom, Comepi never stops developing **ideas and improvements** to create perfect products for specific and demanding applications.

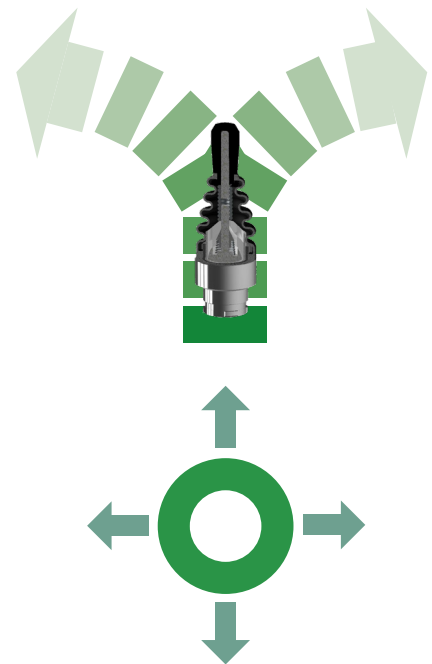

Products

Main features :

- Metal build
- Very resistant
- Suitable for foot control
- Version h. 74 mm



22 mm diameter joystick Applications

Our operational **22mm joysticks** fit any type of applications since they are **sturdy and reliable**.

Over the years, our customers have installed such devices into a number of **machines and equipment**, each one differing from the other.

Their **application flexibility** arises from the variety of available maneuvers and the possible double selection between plastic and metal for their body.

Some Examples of Applications:

- Textile Industry
- Shoe Machinery
- Leather Processing Machinery
- Compactors
- Containers
- Floor Cleaning Machines
- Construction Machinery
- Agricultural Machinery
- Control of Industrial Handling Equipment
- Garage equipment





Comepi

Our figures of 2021

A year that was **rich in success and with great results**.
Thanks to everyone for your trust and support!
Our goal is to further improve in 2022 and **keep growing** in keeping with our company values.



Sales
+ 30%



Productivity
+ 41%



New products
N°7



Staff
+ 12%



Acquired customers
+ 9%



Investments
+ 13%



Our company



Comepi Team

After a demanding 2020 due to the Covid pandemic, Comepi decided **to heavily invest in human resources** in 2021 while aiming at increasing the company competitiveness and skills by enhancing their staff.

With this goal in mind, **Comepi's team was strengthened** with six new resources and other six cooperators were offered a direct work contract.

A new project of **work experience during the school year** was begun that involved a new staff member in our printing department.

A year rich in innovations and success for a company that wats to show how **dynamic, young** it is and **with an incisive female presence**.



+ 6 Direct hired staff



+ 6 Resources in the workforce



+ 1 Work experience during the school year

2021

Our company

Comepi Team Italy Sales Department

Customer-oriented

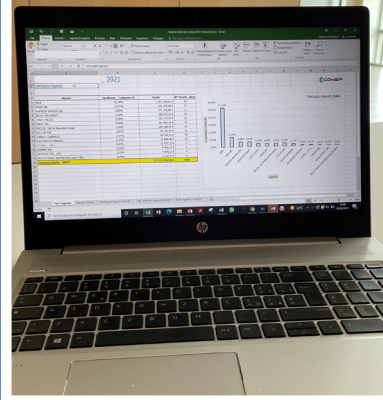

Excellent communication and relation skills



MARKET ANALYSIS



Our company

Dario, after an over 20-year long professional career in different companies, joined Comepi in 2017 as the **Sales Manager in Italy**.

Strongly believing in the potential of this market, he has taken on the challenge of **developing Comepi's presence in the domestic market**.

Family always remains his priority and mountain hiking, sailing, and model making are some of his passions.



In recent years, one of Comepi's main goals was to make all information on our products available to our customers **24 hours a day and 7 days a week**.

Our **online technical catalog**, which we devised along with Cadenas Italiana S.r.l., also plays a key role for our sales and product management teams.

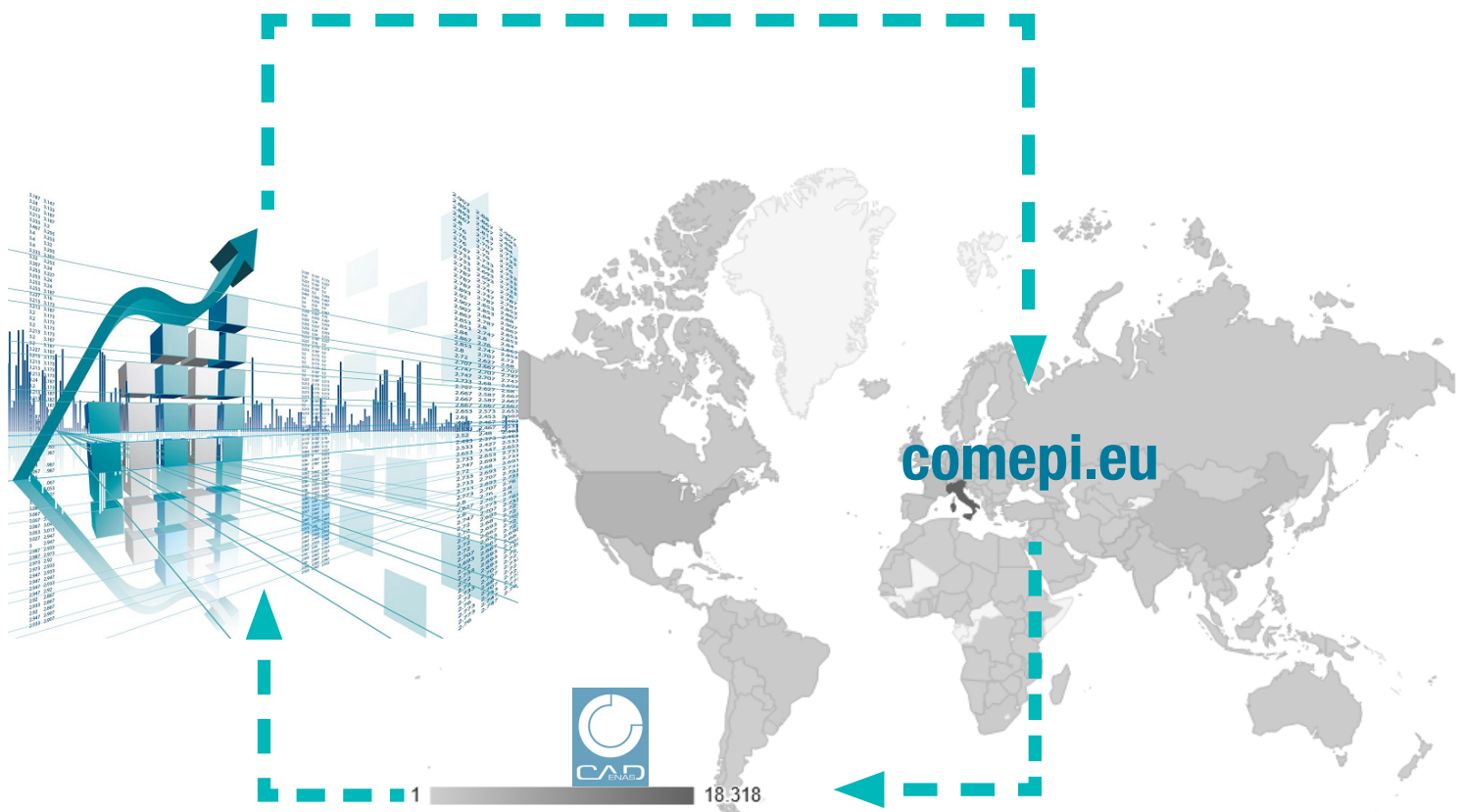

Using statistics on downloads helps Comepi monitor market trends, the steady interest in our products and the increasing number of new customers.

We aim at developing new specific solutions and investing in trade categories that are constantly more alluring, in keeping with the protection of our visitors' privacy.



Augusta, a graduate in Architecture from the Milan Polytechnic, and **Monica**, a graduate in Communication Sciences from Milan University, represent the soul of Comepi Marketing.

Thanks to their shared vision and expertise, they have been devising and realizing projects that **enhance our brand, products and company values** for a year.

Creativity, emotional intelligence, teamwork and a look towards the future are their special skills.

Their motto:

“Whatever the mind of man can conceive and believe, it can achieve”

Napoleon Hill

Comepi's LinkedIn Page

Our Results



7.000 company page views



1.800 single viewers of the company page



73.000 views of our posts



420 total followers, +35% of which in 2021

Our TOP PERFORMING posts:



- Most viewed post : Comepi Team GRETA - 1456 views
- Most clicked on post: Comepi Team MASSIMO - 122 clicks
- Post with highest feedbacks : Comepi talks about DARIO COMI - 35 feedbacks
- Most shared post : An example of THF wireless application - 7 shares
- Most interesting post: Comepi Magazine - 14% of interest



Our company



Comepi Team

Purchasing department



PROBLEM SOLVING



Planing

LEAD TIME

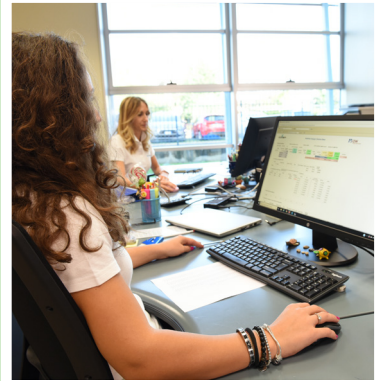

Marta in charge of the Purchasing and Planning Department, and **Mattia**, junior buyer, plan raw material purchases while monitoring the demand evolution. With their **great energy and resolution**, they can ensure proper delivery schedules while coordinating with the production managers. Being both of them very sporty so they

Our company

...together we are a winning team!



Suppliers special



Comepi has always worked with **reliable suppliers**, using only high-quality raw materials.

This choice impacts not only the finished product but also the **service to customers** and the ability to develop new projects. Our **cooperation with LATI** is set in this frame of reference, which is one of the most important European manufacturers of thermoplastic techno polymers. This partnership has granted us the required support over the years to best use the **different types of raw materials**, such as polycarbonate that ensures solidity and resistance, polyamide 66 that allows for production versatility and PBT that offers printing accuracy and several levels of strengthening and fire resistance.



Expertise and experience for best performance!



Our company



Comepi Team

Quality assurance department

ACCURACY

Continual professional updating

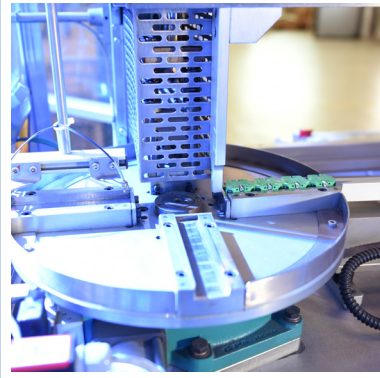

Maximum attention to procedures

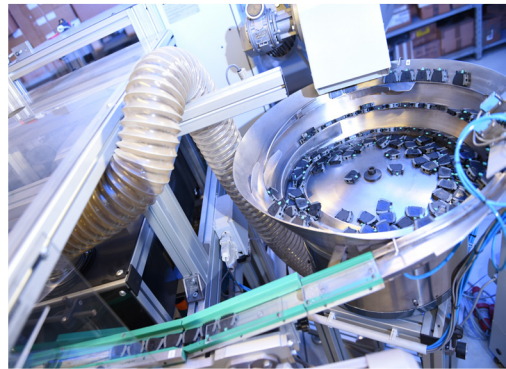

Our company



Francesco, a master's degree in Safety and Prevention Engineering in the Process Industry from the Milan Polytechnic, has been our **Quality Manager** since 2019.

A very competent and precise person, he is in charge of quality, product certification and compliance with domestic and international standards and regulations that are essential requirements to achieve the high-performance level of Comepi products.

A lover of hiking, he does it during his numerous journeys around the world

Comepi LAB

Plastic Component Validation

Our expertise in designing and **injection plastic printing** goes alongside our usual attention to detail and quality. All our components included in Comepi's finished products are accurately **checked and validated** so as to ensure the best performance of our devices.



Attention to quality starts from the very beginning of the production process!

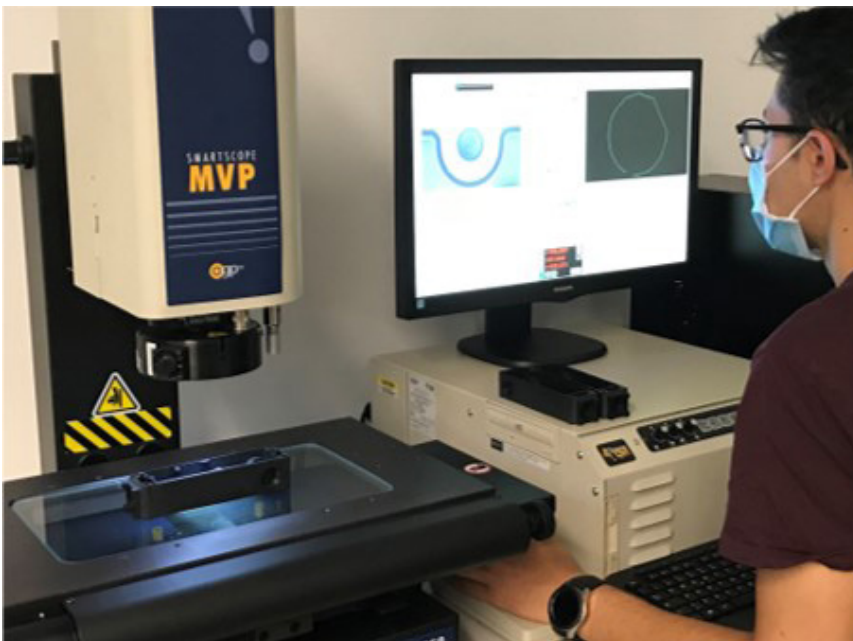

Our company

Comepi Team

Production

Since its inception, Comepi has wanted to establish its role as the **manufacturer of their own products**, which are designed and assembled almost entirely at the company headquarters.

Today, the production department is definitely the **beating heart of the company**, with a dedicated space that takes up more than 5.000 sqm. divided into eight departments per type of product made.

One of the strong points of our production is the management of the assembly of more than 30.000 different standard items in a **quick and flexible way** even in case of complex products that differ according to the required equipment and production cycles. A **working method that is efficient, organized**, and deeply appreciated by our customers as regards service terms and delivery time.



Greta is in charge of the coordination and optimization of operational and design activities and plays a key role at Comepi.

Since 2018, she has been the **Operational Director** working with dedication and success, motivating and supporting her colleagues thanks to her leadership skills.

“A team is not a group of people who work together. A team is a group of people who trust each other.”

Simon Sinek

Comepi Team Production

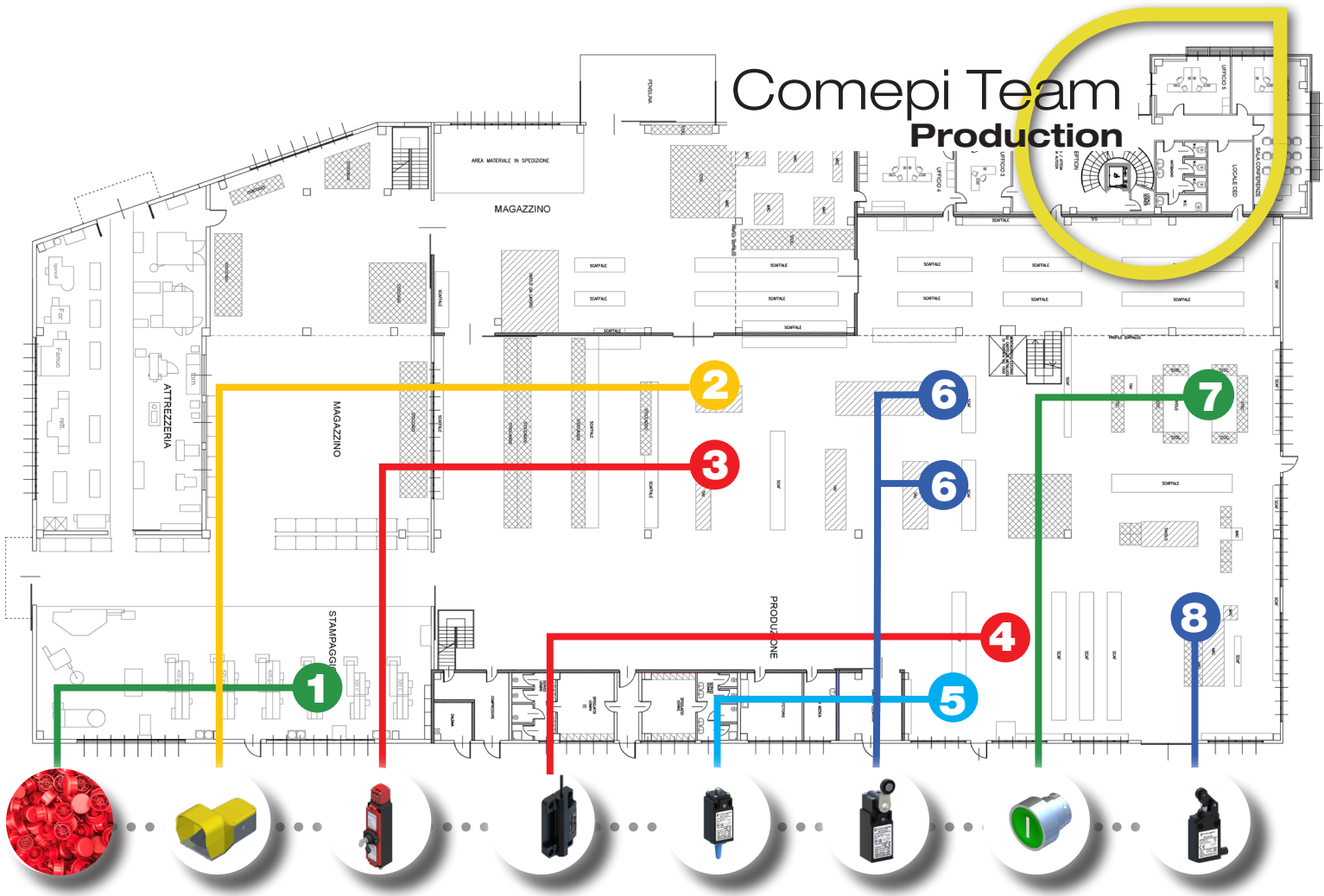

Rosario, technical support to Comepi production, has been with us for 23 years. He is an all-around expert, and he interfaces with the technical area for **new product industrialization** while optimizing the assembling process. His ability to listen and discuss with his colleagues are his distinguishing marks. Motoring is his great passion. For several years he was a race steward in the most important national circuits.



Tooling department

New Wire EDM

Comepi feels it important to invest in the **continual renovation of equipment and machinery** to both ensure product quality and to remain competitive on the market.

With this in mind, a **new wire EDM equipment** has been bought that is essential for the tooling department activities and specifically for the making of molds and production tools.

Being able **to industrialize** industrialize new products quickly and efficiently is an unquestionable leading strength for COMEPI which has always focused on **investments and new ideas.**

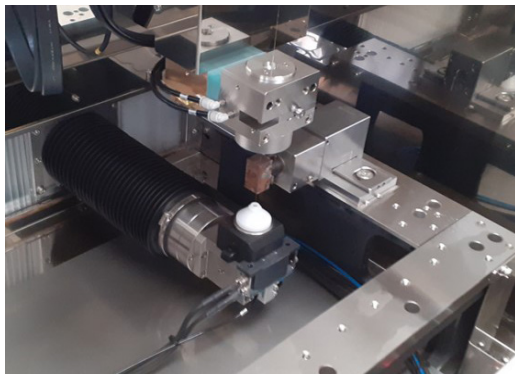

**“COMMITMENT AND THE
UTMOST AVAILABILITY”**

These two terms **Pierangelo's** work for the past 27 years at Comepi. As the Head Toolmaker, he follows the **making of Comepi products molds** so as to always meet very high requirements of quality and accuracy. A mountain lover, he loves hiking and being outdoors in his leisure time.



Our company

Approvals UKCA Marking

As of January 2022, the **UKCA marking** is required to export our type of products to the United Kingdom. Comepi completed all of the necessary procedures to mark their products with the UKCA marking while promptly adapting to the **new standard requisites** and continuing to permit their products to be available on the UK market.

UK CA



our company



WIRELESS & BATTERYLESS system

Application examples

Our innovative series of wireless and battery less products permit improving the workspace, ensuring the operator's better comfort and solving the most diverse application issues.

The companies which chose the products of our wireless battery less system have provided evidence of the foregoing.

switch off your limits

Tecnofruit

An Italian company offering a range of machines specific for fruit picking.

Using a wireless battery less control post allows for controls directly available on mobile platforms, without wiring costs and difficulties.



WIRELESS PUSHBUTTON PANEL



Partnerships





A.A.G.STUCCHI

This Italian company has been designing and manufacturing lighting solution for over 75 years. They use the Comepi wireless system for managing the ANDON system of assistance interventions to online operators in a framework of production management according to the LEAN Manufacturing principles.

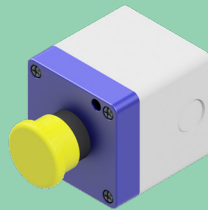

**SW14 WIRELESS
PUSHBUTTON**

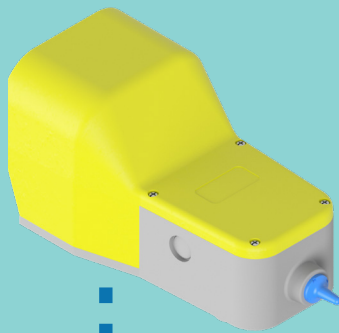

THF

A leading Italian manufacturer of high-frequency welders that decided to use wireless foot switches to remove any potentially dangerous cables from the workspace and position the device where it is most comfortable for the operator.

WIRELESS FOOT SWITCH

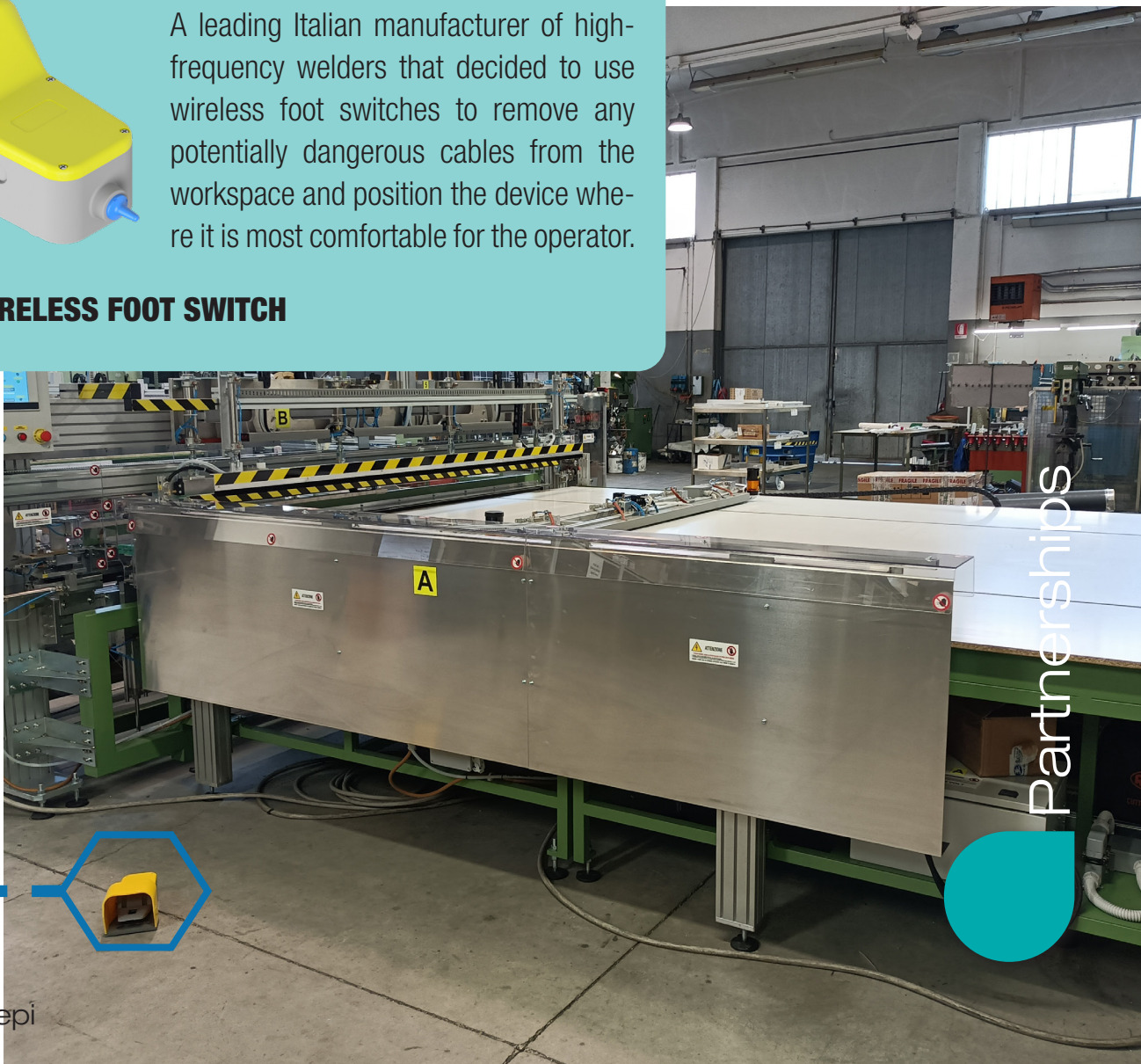

Partnerships

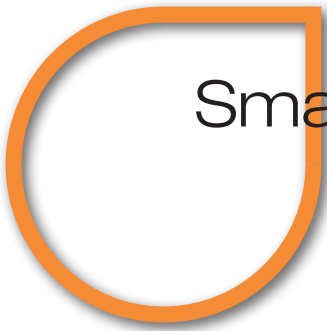

Smart Building Expo 2021

From 22 to 24 November COMEPI attended SMART BUILDING EXPO, the 2021 edition of the Italian tradeshow dedicated to technological integration that took place in the Milan Rho area.

Comepi staff displayed the Wireless Battery less products at the EnOcean Alliance booth.



SMART BUILDING EXPO
22-23-24 novembre 2021
Fiera Milano, Rho



2022 Tradeshow schedule

- **INTERLIFT
2022**

International Tradeshow event dedicated to the Lift industry, including components and accessories. Scheduled in Augsburg, Germany, from 26th to 29th April.

- **SPS Italia
2022**

SPS Italia is the tradeshow for the intelligent, digital and flexible industry, recognized as the reference for the Italian manufacturing sector. Scheduled in Parma from 24th to 26th May.

- **LogiMAT
2022**

LogiMAT is the intra-logistics and process management solutions international tradeshow. It will take place in Stuttgart from 31st May to 2nd June.





Dream your life in color; it's the secret of happiness!



Promises make our future more organized.

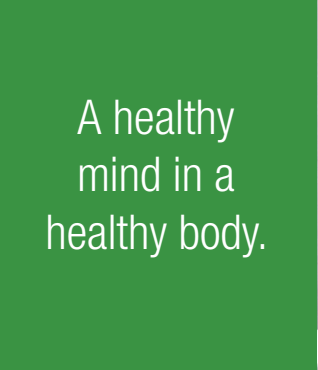

A healthy mind in a healthy body.



It is only with the heart that one can see rightly. What is essential is invisible to the eye.



Life is like riding a bike. After the climb there is always the descent.



Calm is the virtue of the strong.



In the end, it's all a question of balance.



Technology is not perfect. However, it helps improve the quality of your life.



Unity is strength!



Luck is what happens when preparation meets opportunity.



Coming together is a beginning, keeping together is progress, and working together is success.



The power of imagination makes us infinite.

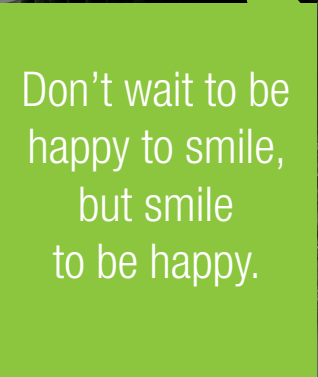

Don't wait to be happy to smile, but smile to be happy.

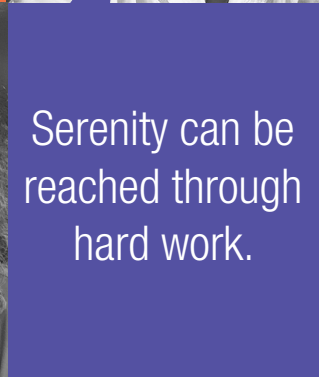

Serenity can be reached through hard work.

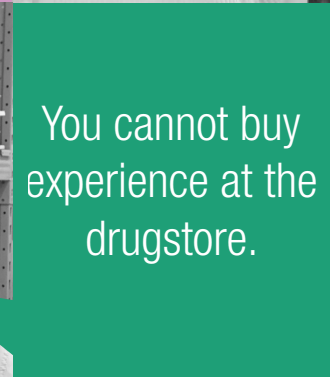

You cannot buy experience at the drugstore.

We are all apprentices in a craft where no one ever becomes a master.



Life less serious!



Always be yourself!!!



Multicolor !!!



I believe in the sun even when it rains.



The world always looks brighter from behind a smile.



Never judge a person on their mistakes but on their desire to correct them.



Tidiness is the basis of everything.



Live and let live!!!



The best freedom is being yourself.



Let everything flow and nothing stand in your way.



Teamwork divides the task and multiplies the success!



If you have choice, then choose the best!



I'm a woman improving herself day by day and competing only with myself.



You learn from making mistakes!



23899 Robbiate (Lecco)
Via Novarino 9/L
tel. +039 9903468
+039 9906408
comepi@comepi.it
comepi.eu



GEN2022-01