

Electrical Connection

AM1: one cable inlet for PG 13,5 Cable Gland

AM2: one cable inlet for 1/2" NPT Cable Gland

AM3: one cable inlet for PG11 Cable Gland

AM4: one cable inlet for M16 x 1,5 Cable Gland

AM5: one cable inlet for M20 x 1,5 Cable Gland



Operating Head Type

	F11 - Plain Metal plunger	F12 - Metal roller plunger	F4• - Ø 18 roller lever F41: nylon roller F43: metal roller
Conformity / (N.C. contact with positive opening operation)	EN 50047	EN 50047	EN 50047
Max actuation speed [m/s]	0,5	0,3	1,5
Min. force [N] or torque [Nm]: actuation / positive opening operation	15 / 30	12 / 30	0,10 / 0,32

Additional Technical Datas

	Order Code	AM•F11Z11	AM•F12Z11	AM•F4•Z11
Z11 Snap Action Contacts (1NO + 1NC)	Operation Diagram 			
X11 Non overlapping Slow Action Contacts (1NO + 1NC)	Operation Diagram 			
Y11 Overlapping Slow Action Contacts (1NO + 1NC)	Operation Diagram 			
W02 Slow Action Contacts (2NC)	Operation Diagram 			
W20 Slow Action Contacts (2NO)	Operation Diagram 			
Z02 Snap Action Contacts (2NC)	Operation Diagram 			
Weight (packing per unit)	[kg]	0,180	0,190	0,235

Dimensions (in mm)

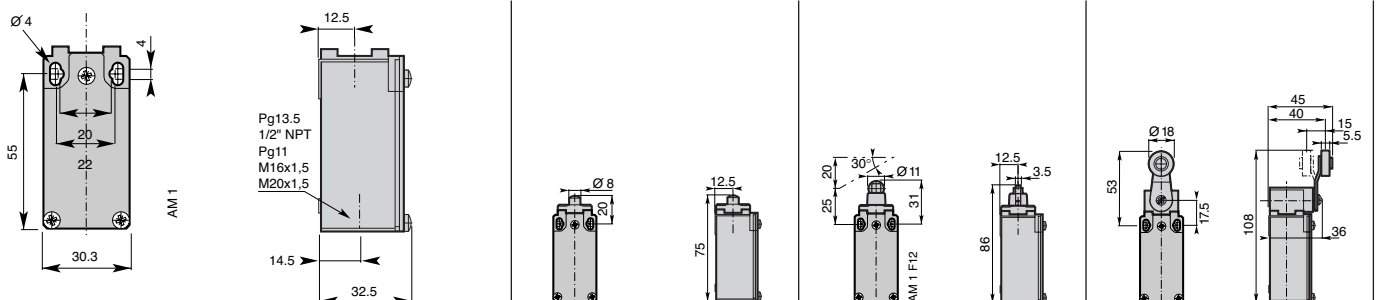



F42 - Ø 50 rubber roller lever



F4 - Ø 18 roller lever
F45: nylon roller
F46: metal roller



F51 - Adjustable Ø 18 nylon roller lever

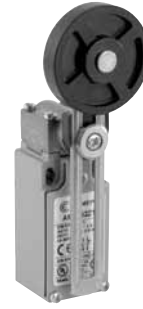

F52 - Adjustable Ø 50 rubber roller lever



F55 - Adjustable lever with adjustable Ø 50 rubber roller

1,5 0,10 / 0,32	1,5 0,10 / 0,32	1,5 0,10 / 0,32	1,5 0,10 / 0,32	1,5 0,10 / 0,32
--------------------	--------------------	--------------------	--------------------	--------------------

<p>AM•F4Z211</p>	<p>AM•F4•Z11</p>	<p>AM•F51Z11</p>	<p>AM•F5Z211</p>	<p>AM•F5Z11</p>
<p>AM•F4Z11</p>	<p>AM•F4•X11</p>	<p>AM•F51X11</p>	<p>AM•F5Z11</p>	<p>AM•F5X11</p>
<p>AM•F4Z11</p>	<p>AM•F4•Y11</p>	<p>AM•F51Y11</p>	<p>AM•F5Z11</p>	<p>AM•F5Y11</p>
<p>AM•F4Z11</p>	<p>AM•F4•W02</p>	<p>AM•F51W02</p>	<p>AM•F5Z11</p>	<p>AM•F5W02</p>
<p>AM•F4Z11</p>	<p>AM•F4•W20</p>	<p>AM•F51W20</p>	<p>AM•F5Z11</p>	<p>AM•F5W20</p>
<p>AM•F4Z11</p>	<p>AM•F4•Z02</p>	<p>AM•F51Z02</p>	<p>AM•F5Z11</p>	<p>AM•F5Z02</p>
0,255	0,250	0,245	0,265	0,265

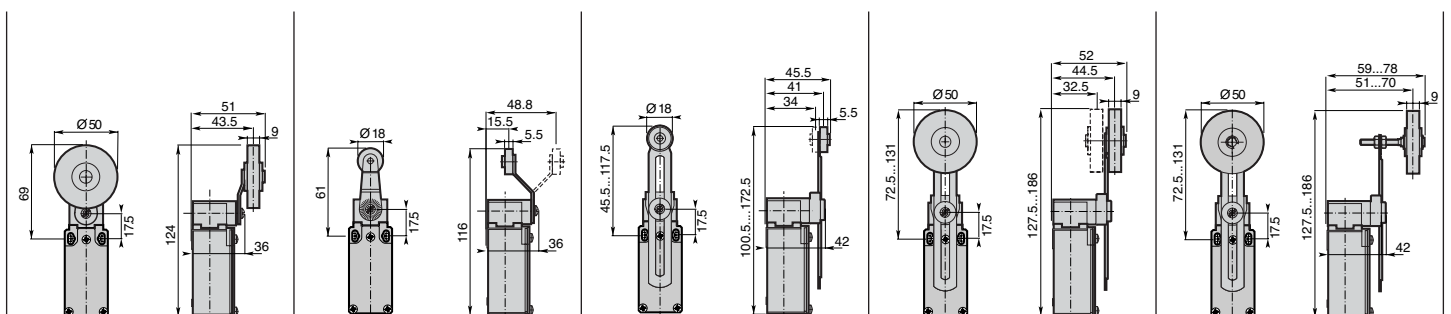

Electrical Connection

AM1: one cable inlet for PG 13,5 Cable Gland

AM2: one cable inlet for 1/2" NPT Cable Gland

AM3: one cable inlet for PG11 Cable Gland

AM4: one cable inlet for M16 x 1,5 Cable Gland

AM5: one cable inlet for M20 x 1,5 Cable Gland



Operating Head Type

F61 - Nylon actuator with stainless steel spring

F7• - Adjustable rod lever

F71: stainless steel rod Ø3
F72: fiberglass rod Ø3
F75: square steel rod 3x3

F7• - Adjustable Ø 6 rod lever

F73: nylon rod
F74: fiberglass rod







Conformity / \odot (N.C. contact with positive opening operation)
Max actuation speed [m/s]
Min. force [N] or torque [Nm]: actuation / positive opening operation

1,5
0,10 / -

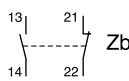
1,5
0,10 / 0,32

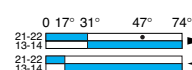
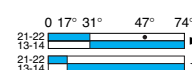
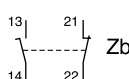
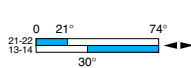
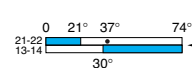
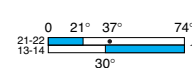
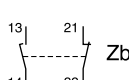
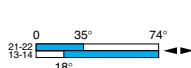
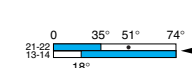
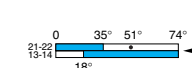
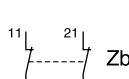
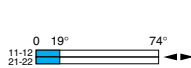
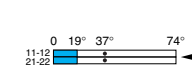
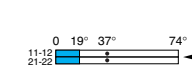
1,5
0,10 / 0,32

Additional Technical Datas

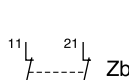
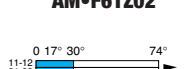
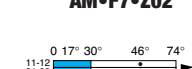
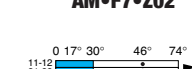
	Order Code	AM•F61Z11	AM•F7•Z11	AM•F7•Z11
Z11 Snap Action Contacts (1NO + 1NC) 	Operation Diagram			
X11 Non overlapping Slow Action Contacts (1NO + 1NC) 	Operation Diagram			
Y11 Overlapping Slow Action Contacts (1NO + 1NC) 	Operation Diagram			
W02 Slow Action Contacts (2NC) 	Operation Diagram			
W20 Slow Action Contacts (2NO) 	Operation Diagram			
Z02 Snap Action Contacts (2NC) 	Operation Diagram			
Weight (packing per unit)	[kg]	0,245	0,245	0,255

Dimensions (in mm)

